

Unit-3
Kinematics Analysis of Mechanisms:
Graphical Methods
Subject: Kinematics of Machinery

Mr. D. S. Lengare

Assistant Professor, Automobile Engineering Department
Government College of Engineering & Research, Awasari
khurd.

Relative Velocity Method

As shown in fig (a),
Consider two bodies A and B
moving in different directions
with absolute velocities v_A and v_B .

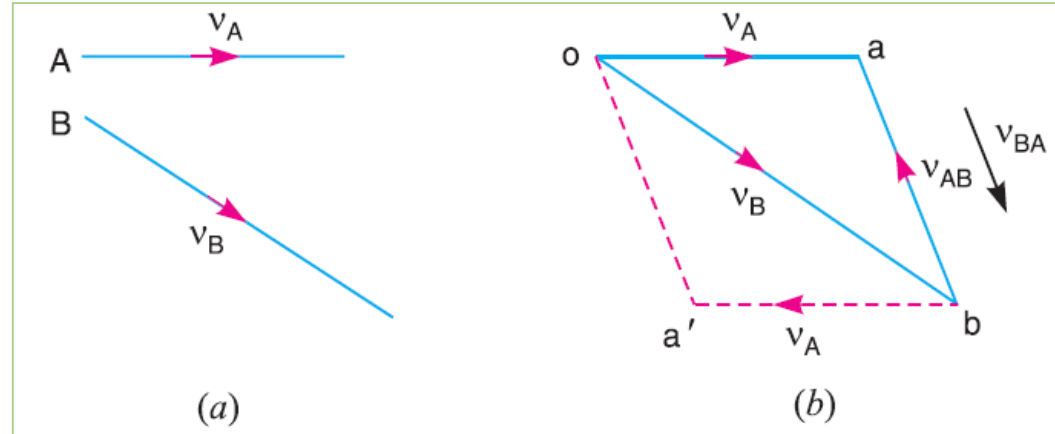

The relative velocity of body A with respect to B (v_{AB}) may be obtained by law of parallelogram of velocities or triangle law of velocities. [Fig (b)]

$$v_{AB} = \text{Vector difference of } v_A \text{ and } v_B = \overline{v_A} - \overline{v_B}$$

$$\overline{ba} = \overline{oa} - \overline{ob}$$

Similarly, relative velocity of body B wrt A (v_{BA}) [Fig (b)]

$$v_{BA} = \text{Vector difference of } v_B \text{ and } v_A = \overline{v_B} - \overline{v_A}$$

$$\overline{ab} = \overline{ob} - \overline{oa}$$

v_{AB} and v_{BA} are

equal in Magnitude but
opposite in Direction

$$v_{AB} = -v_{BA}$$

$$\overline{ba} = -\overline{ab}$$

**It may be noted that ,
to find v_{AB} start from point b towards a and
to find v_{BA} start from point a towards b**

Relative Velocity Method

Velocity of any point on a link with respect to another point on same link is always perpendicular to line joining these points on the Link.

Let ω = angular Velocity of Link about A

So,

Velocity of B wrt A

$$v_{BA} = \text{vector } ab = \omega \cdot AB$$

Velocity of C wrt A

$$v_{CA} = \text{vector } ac = \omega \cdot AC$$

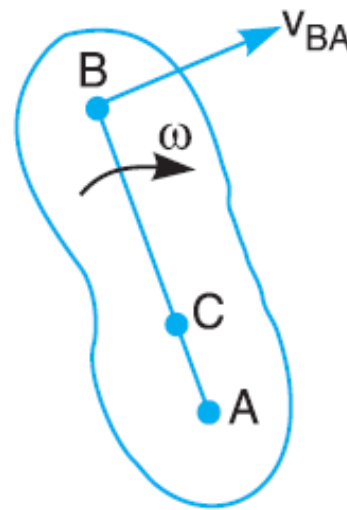

(a)

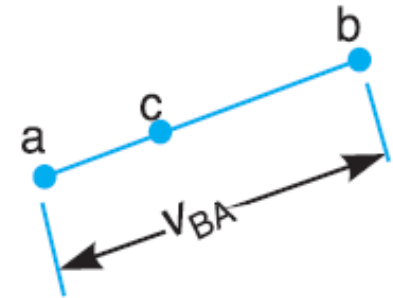

(b)

$$\frac{v_{CA}}{v_{BA}} = \frac{ac}{ab} = \frac{AC}{AB}$$

Relative Velocity Method (Graphical Method)

Velocity of any point on a link with respect to another point on same link is always perpendicular to line joining these points on the Link.

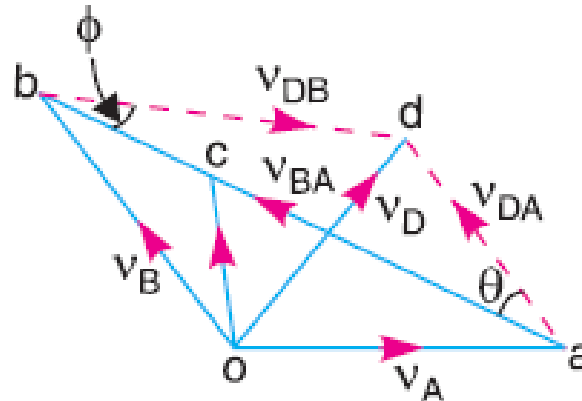
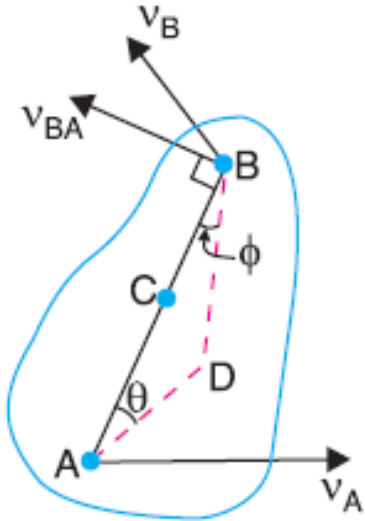

1. Draw oa
2. Draw ab perpendicular to AB
3. Draw ob parallel to v_B , to intersect at b

Fig (a) Motion of Points on Link

Fig (b) Velocity Diagram

Relative Velocity of point B wrt A = vector ab

Angular Velocity of Link AB

$$\omega_{AB} = \frac{v_{BA}}{AB} = \frac{ab}{AB}$$

$$\frac{ac}{ab} = \frac{AC}{AB}$$

Vector oc represents absolute velocity of Point C on Link AB

Velocities in Slider Crank Mechanism

Velocity of any point on a link with respect to another point on same link is always perpendicular to line joining these points on the Link.

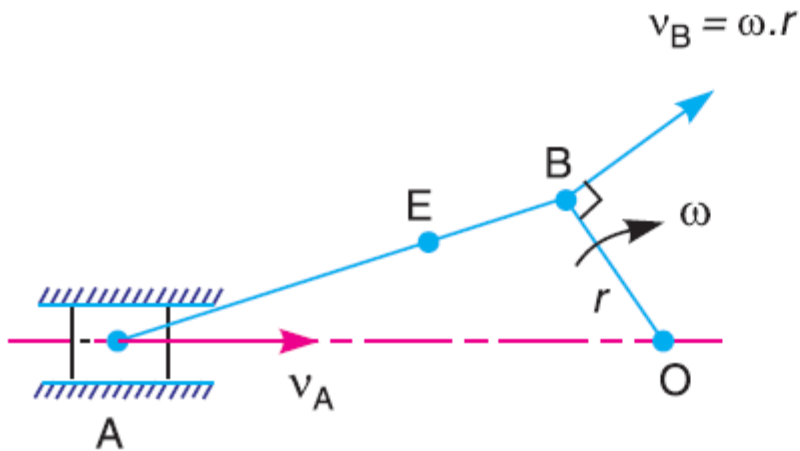

(a) Slider crank mechanism.

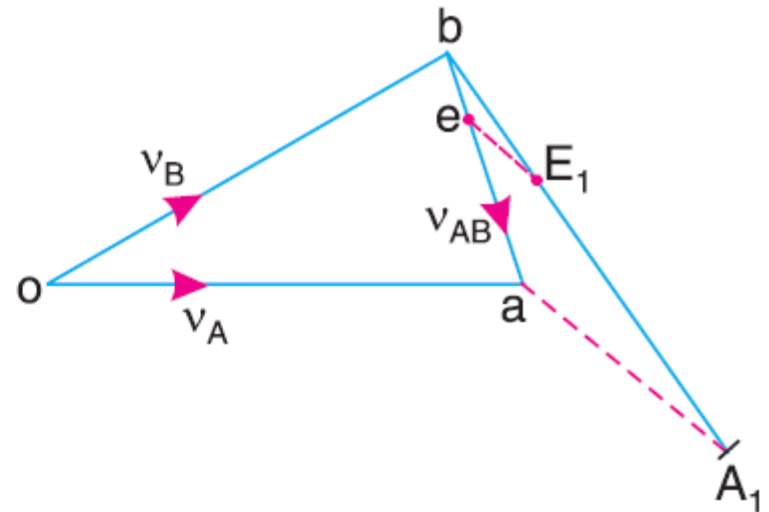

(b) Velocity diagram.

Angular Velocity of Link AB

$$\omega_{AB} = \frac{v_{BA}}{AB} = \frac{ab}{AB}$$

$$\frac{ae}{ab} = \frac{AE}{AB}$$

Vector oe represents absolute velocity of Point E on Link AB

Numerical 5.1

In a Four-bar Chain ABCD, AD is fixed and is 150 mm long. The Crank AB is 40 mm long and rotates at 120 rpm clockwise, while the link CD = 80 mm oscillates about D. BC and AD are of equal length

Find the angular velocity of link CD when angle BAD = 60°

Solution:

Step 1: Draw Space diagram to some suitable scale as in fig (a)

Step 2: Calculate $v_B = r \cdot \omega_{AB} = r \cdot 2 \cdot \pi \cdot N / 60$ m/s

Step 3: Draw Velocity Diagram fig (b), with suitable scale

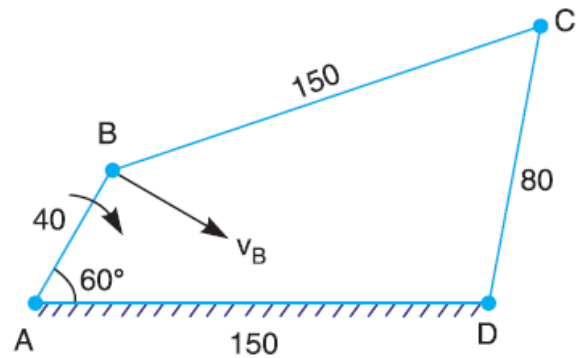

Fig (a) Space Diagram

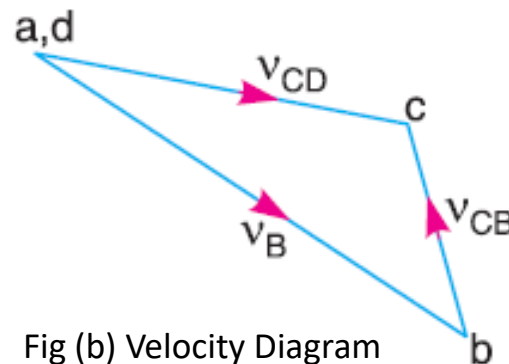

Fig (b) Velocity Diagram

Step 4:

From fig (b),
measure vector dc i.e. v_{CD}

Then calculate

Angular velocity of Link CD,

$$\begin{aligned}\omega_{CD} &= v_{CD} / DC \\ &= \mathbf{4.8} \text{ rad/sec (Clockwise)}\end{aligned}$$

Sliding Velocity at a PIN Joint

Sliding Velocity is defined as

Algebraic sum between angular velocities of two links which are connected by PIN joints, multiplied by radius of PIN

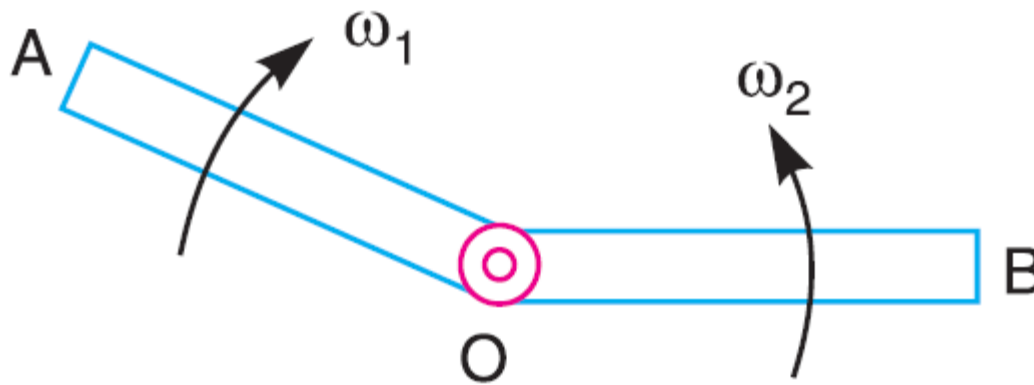

Sliding Velocity at pin joint O

$$= (\omega_1 + \omega_2) \cdot r$$

$$= (\omega_1 - \omega_2) \cdot r \quad \text{If Links move in same direction}$$

Sliding Velocity at a PIN Joint

Sliding Velocity is defined as

Algebraic sum between angular velocities of two links which are connected by PIN joints, multiplied by radius of PIN

When PIN connects one sliding member and the other turning member, the angular velocity of sliding member is ZERO

In such cases,

$$\text{Sliding Velocity} = \omega.r$$

Numerical 5.2

In given fig, the angular velocity of crank OA is 600 rpm . Determine the linear velocity of the slider D and the angular velocity of the link BD, when the crank is inclined at an angle of 75° to the vertical. The dimensions of various links are $OA = 28 \text{ mm}$, $AB = 44 \text{ mm}$, $BC = 49 \text{ mm}$ and $BD = 46 \text{ mm}$. The centre distance between the centers of rotation O and C is 65 mm . The path of travel of the slider is 11 mm below the fixed point C. The slider moves along a horizontal path and OC is vertical.

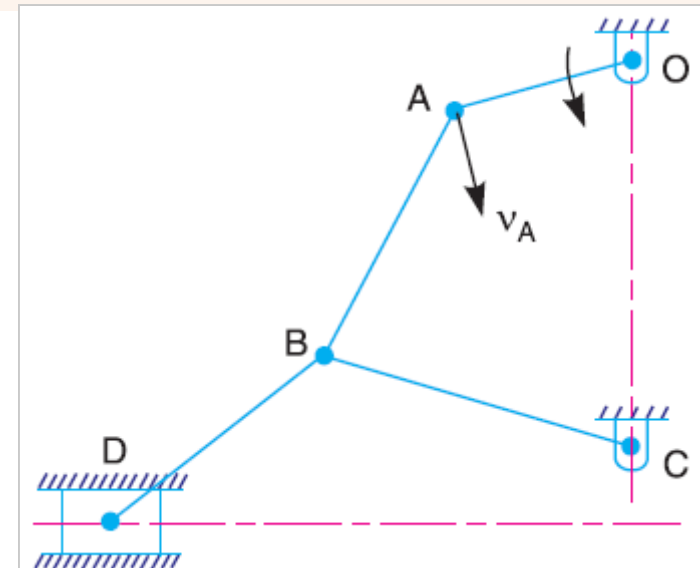
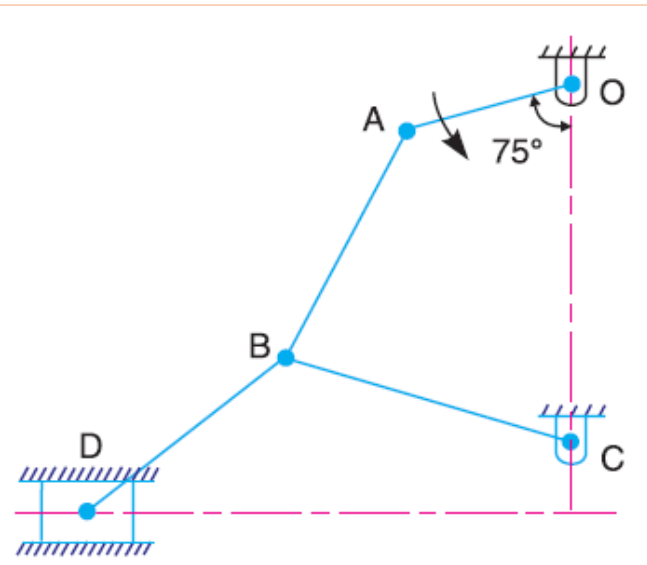

Fig (a) Space Diagram

Solution:

Step 1: Draw Space diagram to some suitable scale as in fig (a)

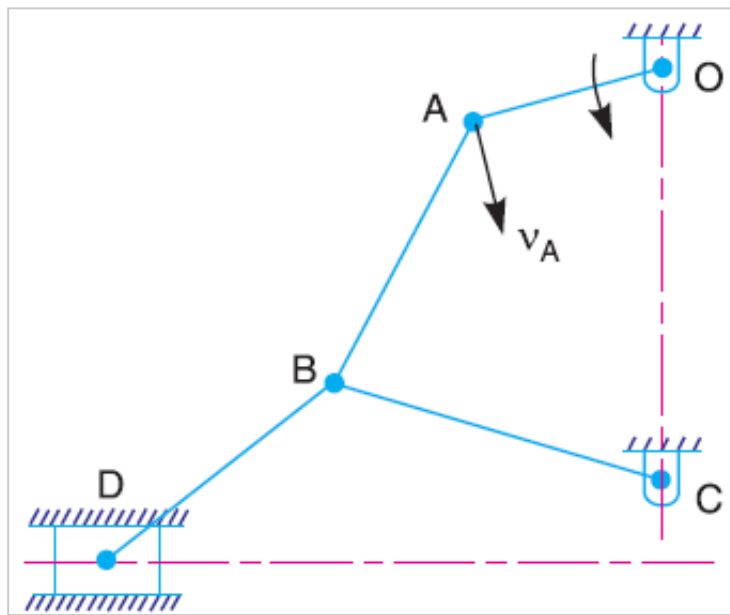

Fig (a) Space Diagram

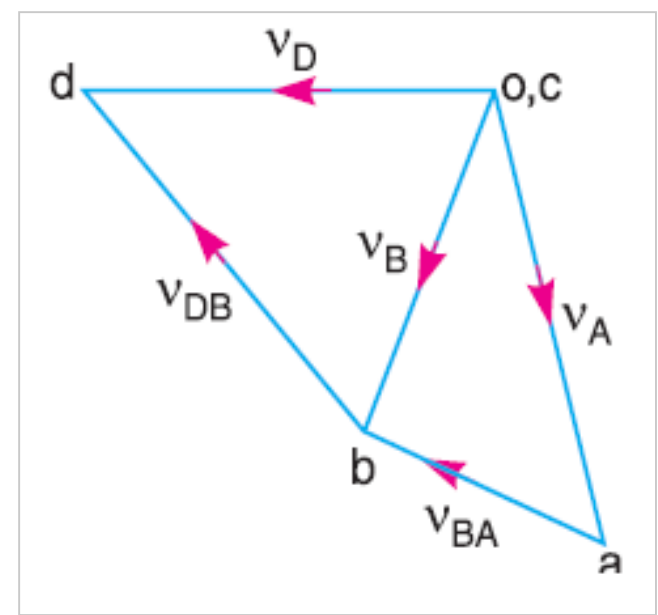

Fig (b) Velocity Diagram

Step 2: Calculate $v_A = r \cdot \omega_{OA} = r \cdot 2 \cdot \pi \cdot N / 60 \text{ rad/sec}$

Step 3: Draw Velocity Diagram fig (b), with suitable scale

Step 4: Measure cd i.e. $v_D = \text{vector } cd = 1.6 \text{ m/s}$

Step 5: Measure bd i.e. v_{DB}

Step 6: Angular Velocity, $\omega_{DB} = v_{DB}/BD =$

36.96 rad/sec (Clockwise about B)

Numerical with Swivel Joint

Numerical 5.3

In given mechanism, OA is driving crank rotating at 200 rpm. The lengths of various links are OA = 2.5 cm, AB = 18 cm, AD = DB, DE = 10 cm, BC = 6 cm and EF = 10 cm.

The horizontal distance between O and C is 15 cm,

Vertical distance between O and F is 12 cm.

Determine for configuration, when OA makes 45° with the horizontal

- Velocity of Slider block F;
- Angular velocity of Link DE;
- Velocity of Sliding of Link DE in Swivel Block

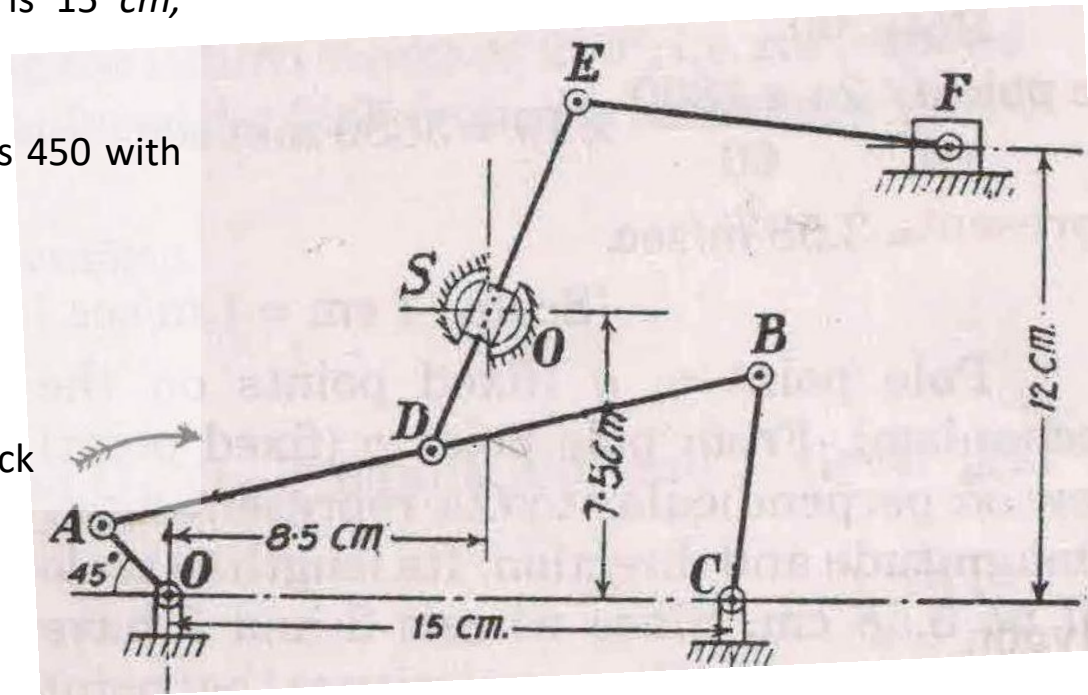

Numerical with Swivel Joint

Solution:

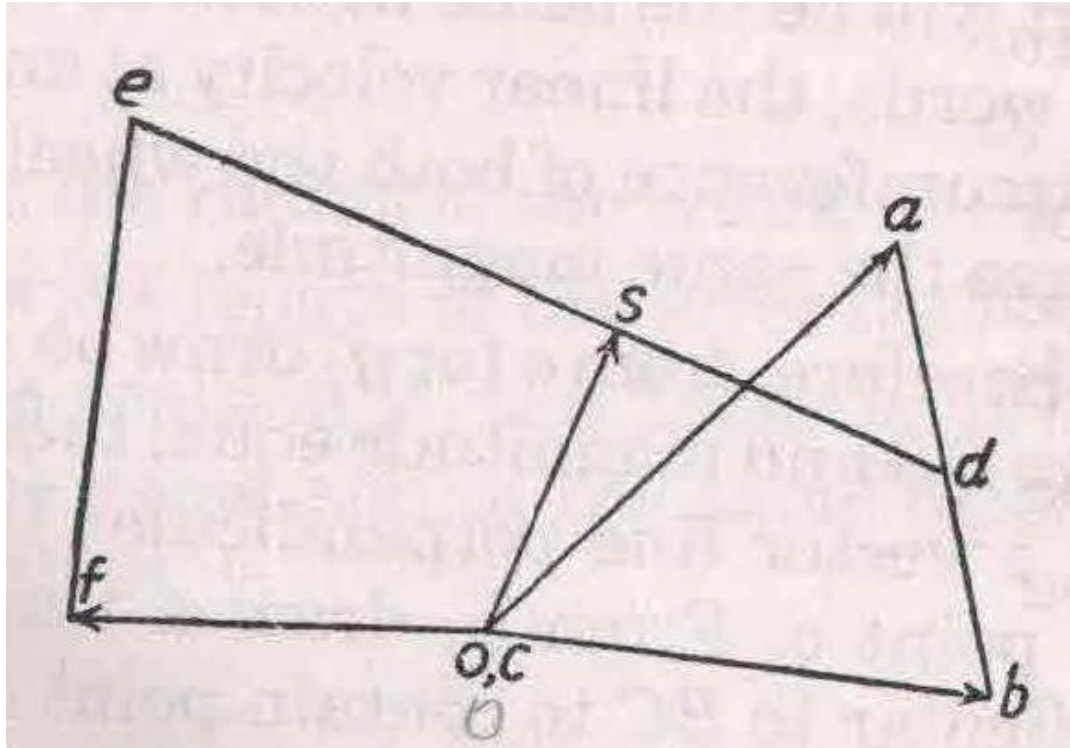

Velocity Polygon

$$VF = \text{vector } of = 39 \text{ cm/s.}$$

$$\text{Angular Velocity of Link DE} = \text{vector } de/DE = 8.25 \text{ rad/sec.}$$

$$VS = \text{vector } os = 30.5 \text{ cm/s.}$$

Relative Acceleration Method

Consider (Fig a) Point B on Link moves with respect to A, with

$\omega = \text{Angular Velocity, rad/sec.}$

$\alpha = \text{Angular acceleration, rad/sec}^2$

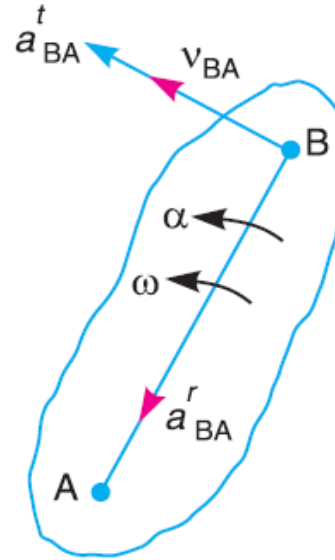

(a)

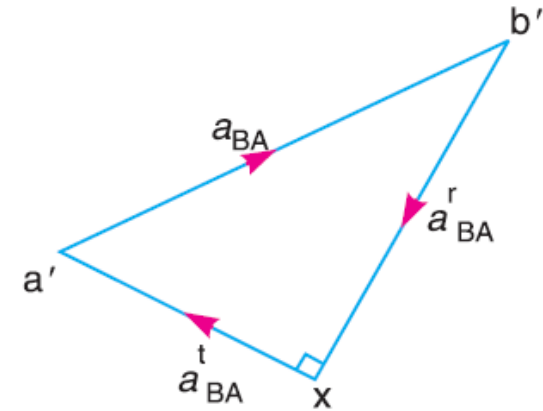

(b)

Acceleration of particle, whose velocity changes both in magnitude and direction at any instant, **has following two components** (Fig b)

1) **Radial Component ($b'x$)**, perpendicular to velocity (V_{BA}) of particle

$$a_{BA}^r = \omega^2 \cdot AB = \frac{v_{BA}^2}{AB}$$

2) **Tangential Component (xa')**, parallel to velocity (V_{BA}) of particle

$$a_{BA}^t = \alpha \cdot AB$$

Acceleration of a POINT on a Link

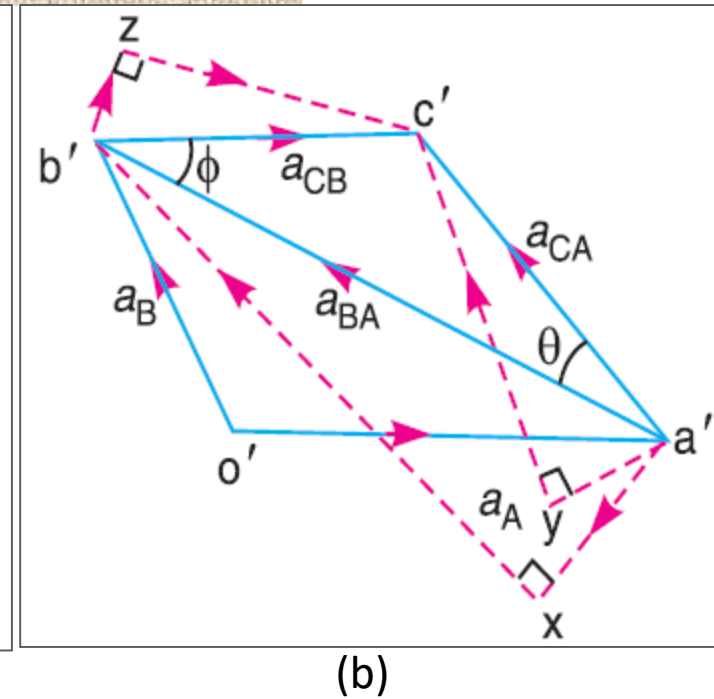
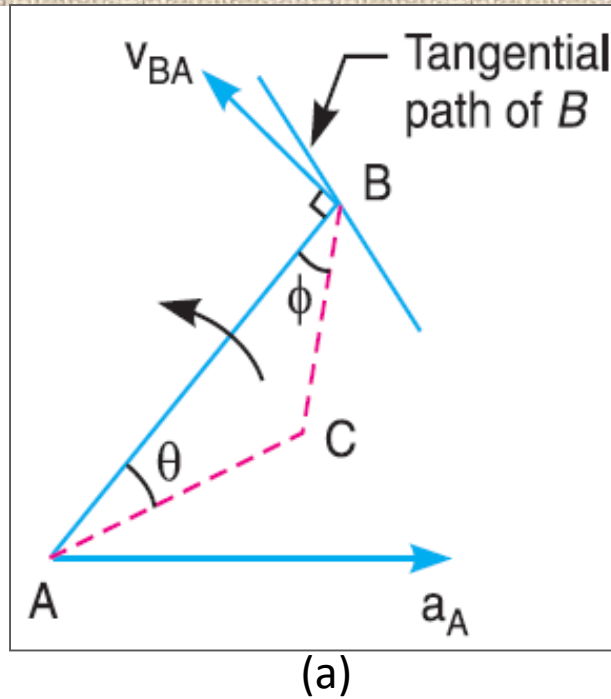

Consider (Fig a)
Point A moves with Accl a_A known in magnitude and direction.
Direction of path of B is given, Accl of B can be determined.

Acceleration of B with respect to A has following two components (Fig b)

1) **Radial Component (a'_x)**, perpendicular to velocity (v_{BA}) of particle

$$a_{BA}^r = \omega^2 \cdot AB = \frac{v_{BA}^2}{AB}$$

2) **Tangential Component (xb')**, parallel to velocity (v_{BA}) of particle

$$a_{BA}^t = \alpha \cdot AB$$

Numerical 5.4 . The crank of a slider crank mechanism rotates clockwise at a constant speed of 300 r.p.m. The crank is 150 mm and the connecting rod is 600 mm long. Determine : **1.** linear velocity and acceleration of the midpoint of the connecting rod, and **2.** angular velocity and angular acceleration of the connecting rod, at a crank angle of 45° from inner dead centre position.

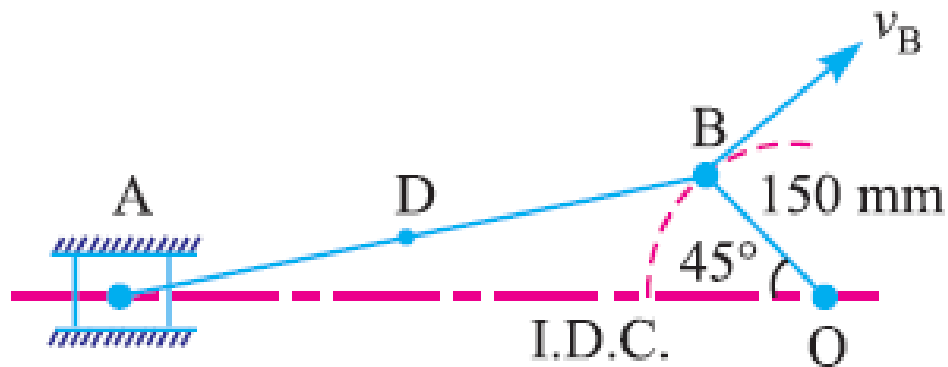

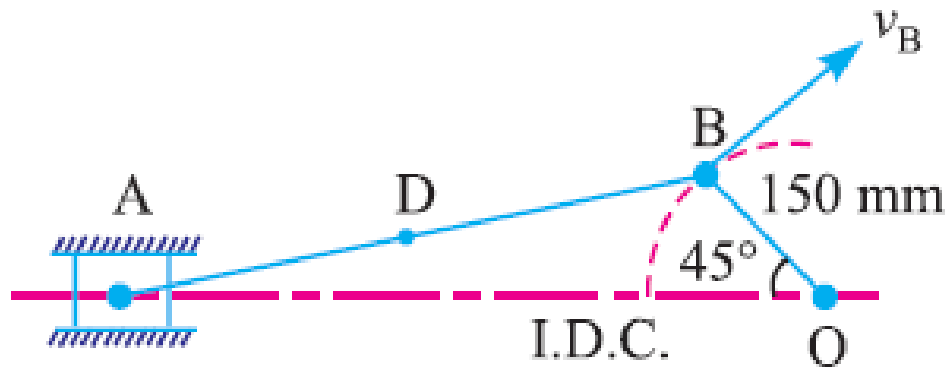

Space Diagram

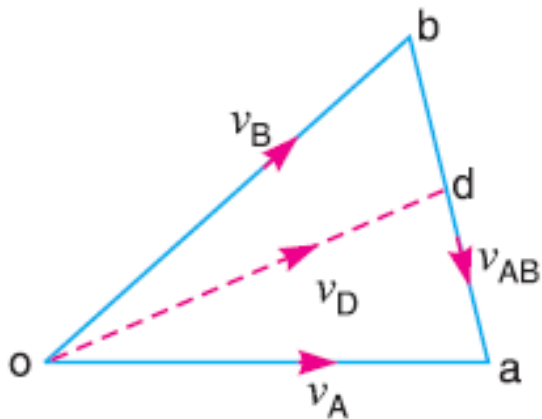

Velocity Diagram

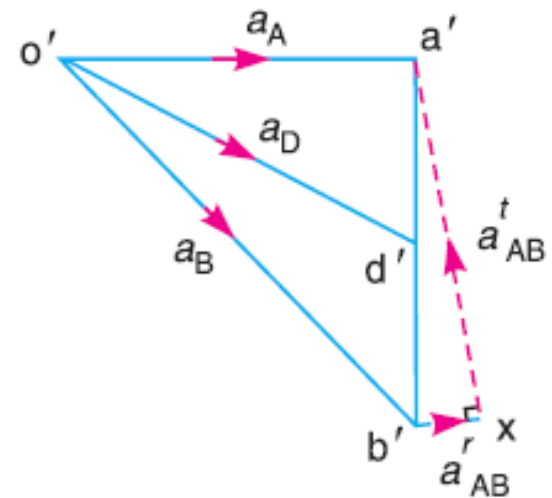

Acceleration Diagram

Linear Velocity of D = 4.1 m/s
Linear Acceleration of = 117 m/s²

Angular Velocity of AB = 5.67 rad/sec
Angular Acceleration of AB = 171.67 rad/sec²

Numerical 5.5 . *PQRS is a four bar chain with link PS fixed. The lengths of the links are $PQ = 62.5 \text{ mm}$; $QR = 175 \text{ mm}$; $RS = 112.5 \text{ mm}$; and $PS = 200 \text{ mm}$. The crank PQ rotates at 10 rad/s clockwise. Draw the velocity and acceleration diagram when angle $QPS = 60^\circ$ and Q and R lie on the same side of PS . Find the angular velocity and angular acceleration of links QR and RS .*

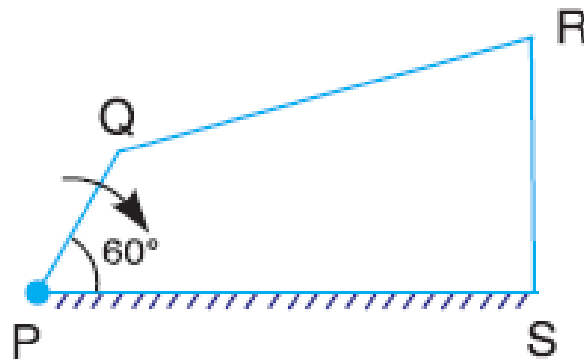

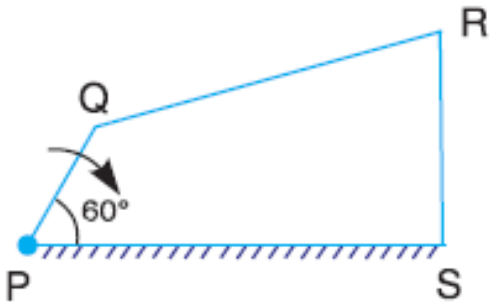

Space Diagram

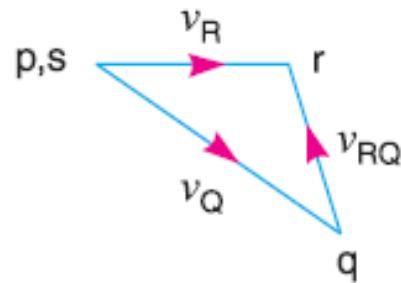

Velocity Diagram

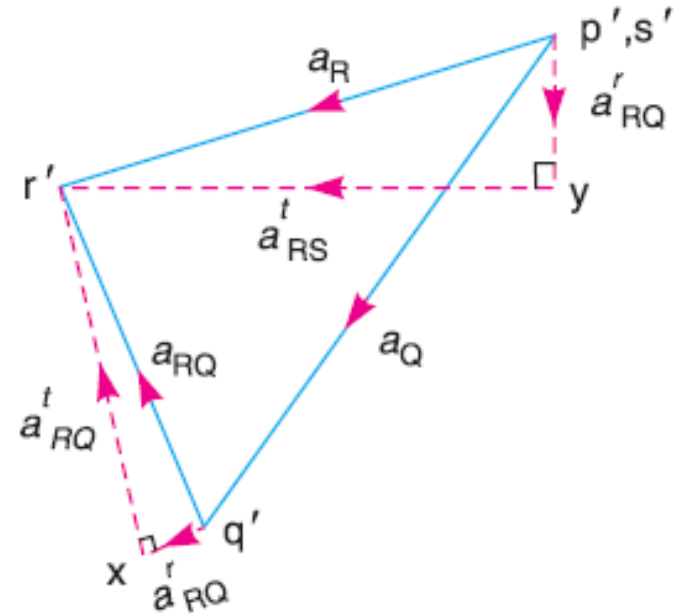

Acceleration Diagram

Angular Velocity of QR = 1.9 rad/sec [CC]

Angular Velocity of RS = 3.78 rad/sec [C]

Angular Acceleration of QR = 23.43 rad/sec² [CC]

Angular Acceleration of RS = 47.1 rad/sec² [CC]

Numerical 5.6

The mechanism of a warping machine, as shown in Fig. has the dimensions as follows:

$O_1A = 100 \text{ mm}$; $AC = 700 \text{ mm}$; $BC = 200 \text{ mm}$; $BD = 150 \text{ mm}$; $O_2D = 200 \text{ mm}$; $O_2E = 400 \text{ mm}$; $O_3C = 200 \text{ mm}$.

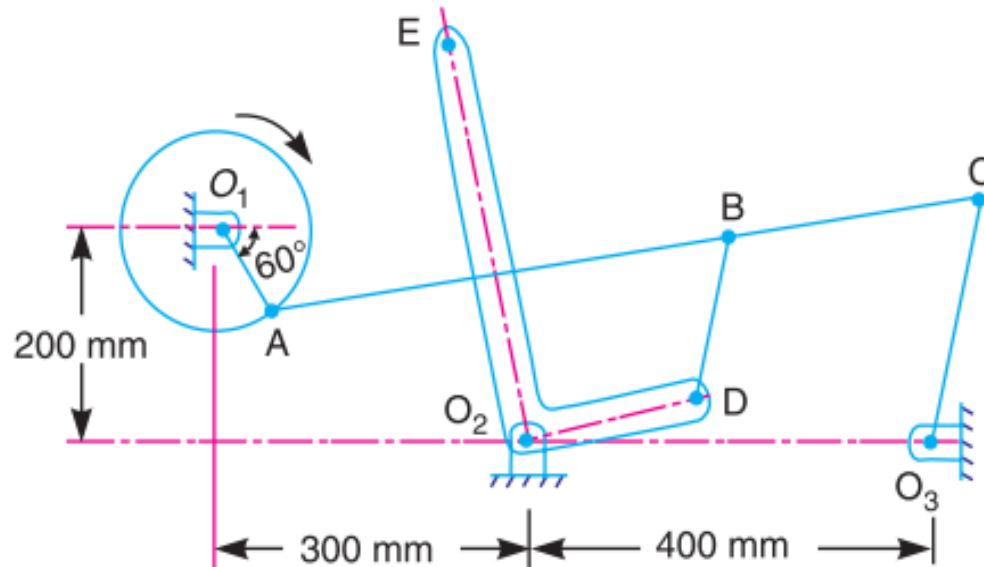

The crank O_1A rotates at a uniform speed of 100 rad/s . For the given configuration, determine: **1.** linear velocity of the point E on the bell crank lever, **2.** acceleration of the points E and B , and **3.** angular acceleration of the bell crank lever.

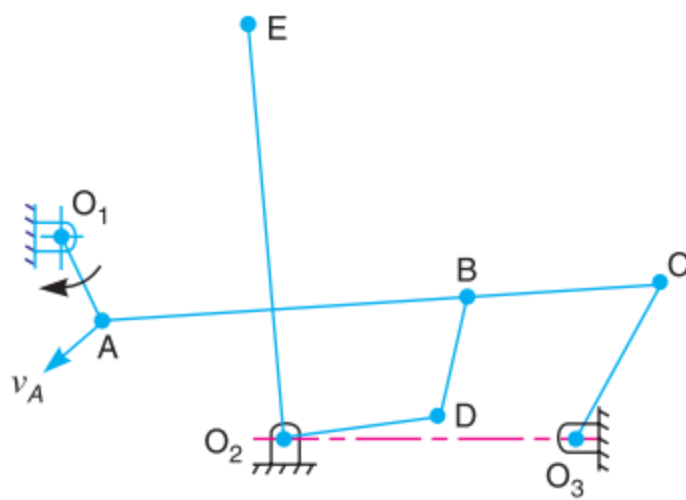

(a) Space diagram.

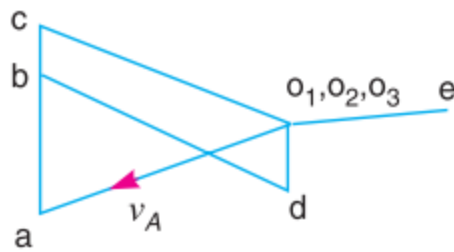

(b) Velocity diagram.

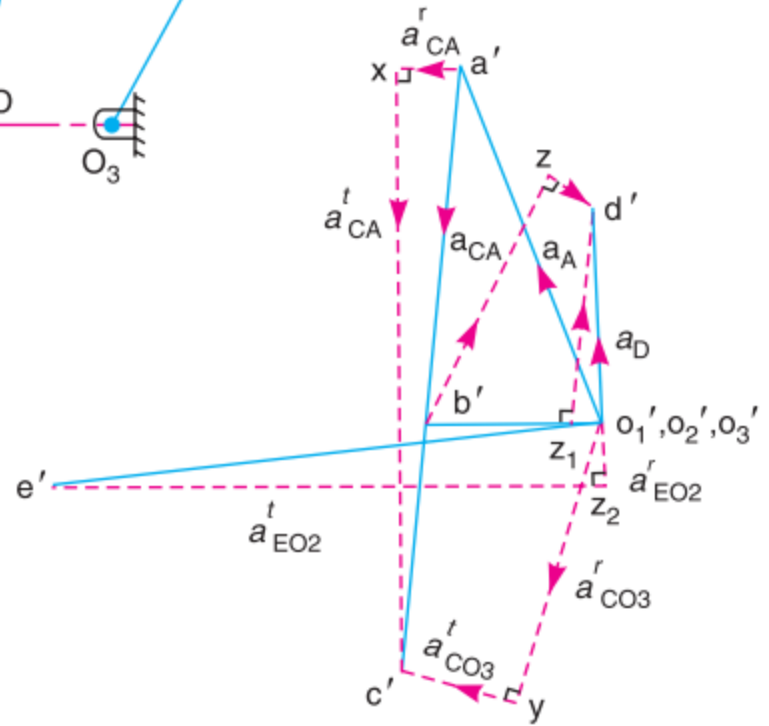

(c) Acceleration diagram.

Velocity of E = 5.8 m/s

Acceleration of E = 440 m/s²

Acceleration of B = 1200 m/s²

Angular Acceleration of DO₂E = 3050 rad/sec² [CC]

Instantaneous Center of Rotation (ICR) Method

Velocity of a POINT on a Link

$$\frac{v_A}{AI} = \frac{v_B}{BI} = \frac{v_C}{CI}$$

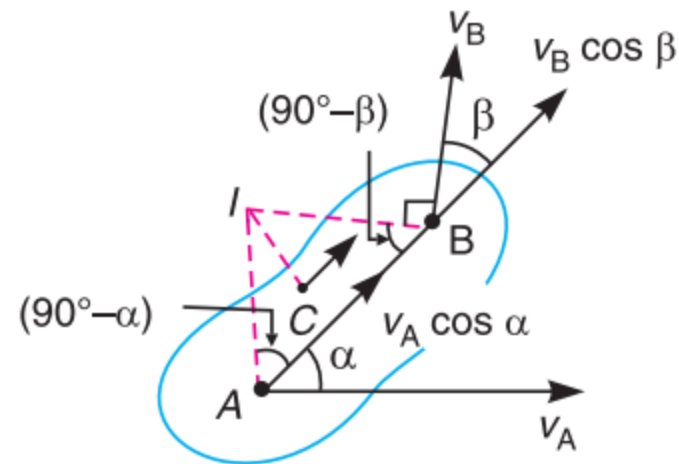

Number of ICR's in a Mechanism

$$N = \frac{l(l-1)}{2}$$

Where l = Number of Links

Types of ICR's

1. Fixed ICR
2. Permanent ICR
3. Neither Fixed nor Permanent ICR

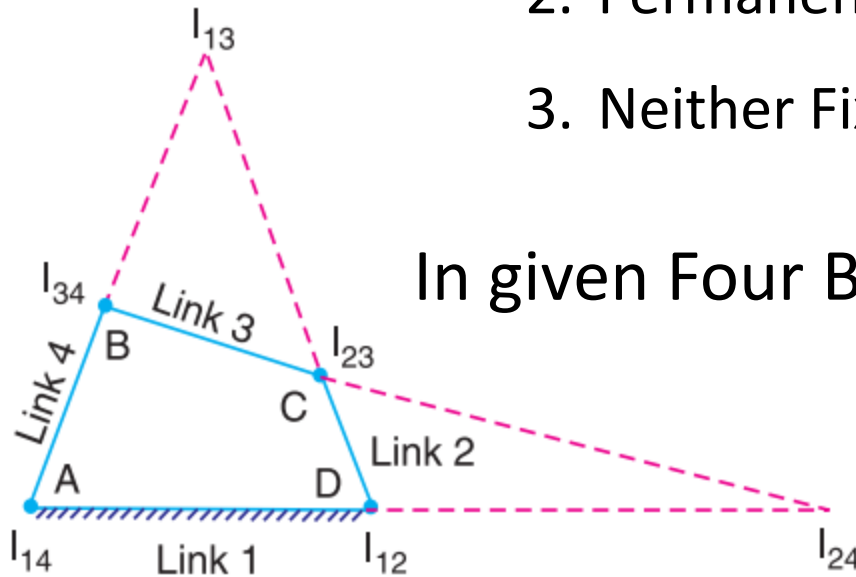

1. Fixed ICR : I_{14}, I_{12}
2. Permanent ICR : I_{34}, I_{23}
3. Neither Fixed nor Permanent ICR : I_{13}, I_{24}

How to locate ICR's in Mechanism

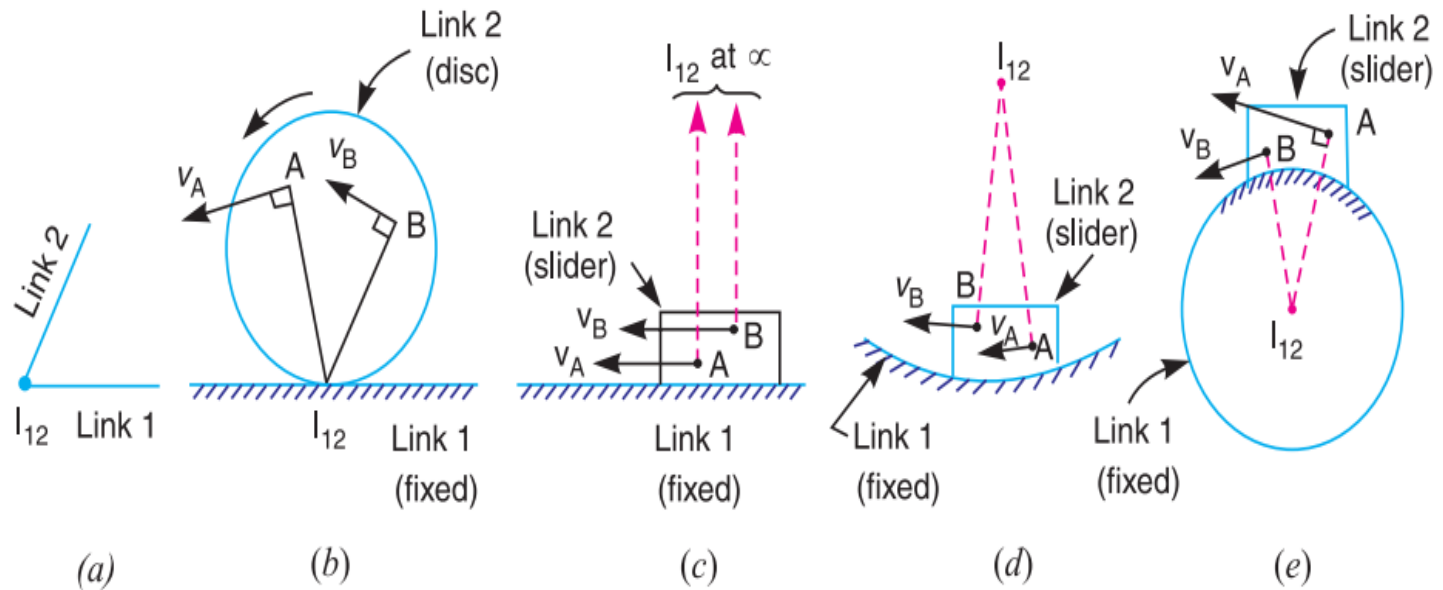

Aronhold Kennedy (Three Centres in-line) Theorem

If three bodies move relatively to each other they have three ICR's and lie on a straight line

Numerical 5.7 The mechanism of a wrapping machine, as shown in Fig. , has the following dimensions :

$O_1A = 100 \text{ mm}$; $AC = 700 \text{ mm}$; $BC = 200 \text{ mm}$; $O_3C = 200 \text{ mm}$; $O_2E = 400 \text{ mm}$; $O_2D = 200 \text{ mm}$ and $BD = 150 \text{ mm}$.

The crank O_1A rotates at a uniform speed of 100 rad/s . Find the velocity of the point E of the bell crank lever by instantaneous centre method.

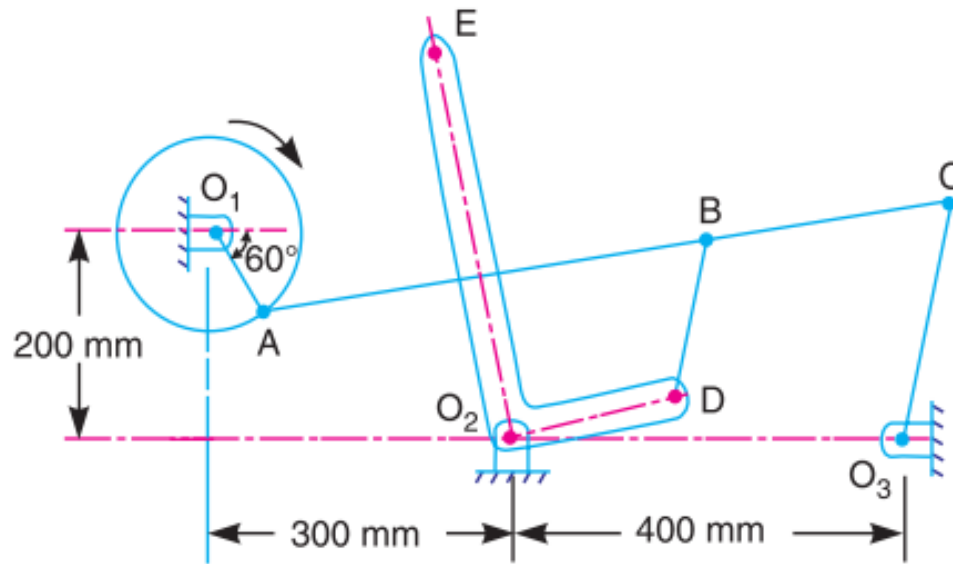

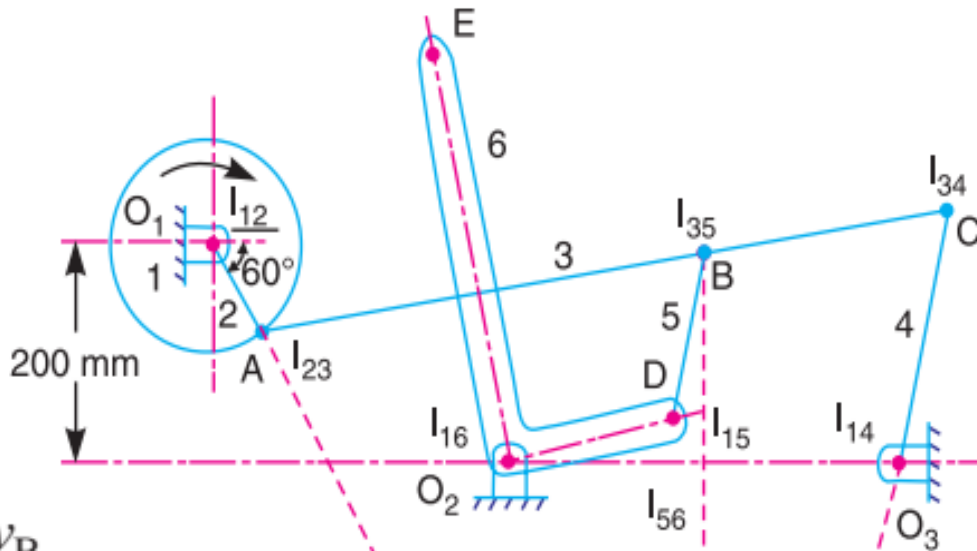

We know that

$$\frac{v_A}{I_{13} A} = \frac{v_B}{I_{13} B}$$

And
$$\frac{v_B}{I_{15} B} = \frac{v_D}{I_{15} D}$$

Similarly,

$$\frac{v_D}{I_{16} D} = \frac{v_E}{I_{16} E}$$

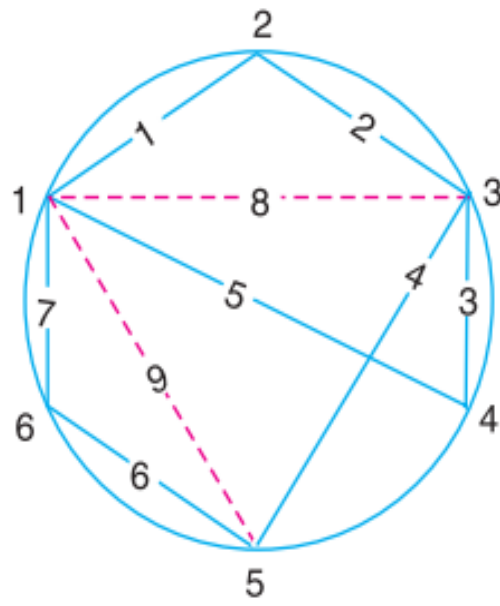

Velocity of E = 6.92 m/s

ACCELERATION OF PARTICLE ALONG A CIRCULAR PATH:-

Consider A and B ,the two positions of a particle displaced through an angle $\delta\theta$
In time δt Let,

r = radius of curvature of circular path.

v = velocity of the particle at A, and

$v + \delta v$ = velocity of particle at B.

The change of velocity may be obtained by drawing the vector triangle oab as shown. oa represents velocity of v and ob represent velocity of $v + \delta v$. The change of velocity in time δt is represented by ab .

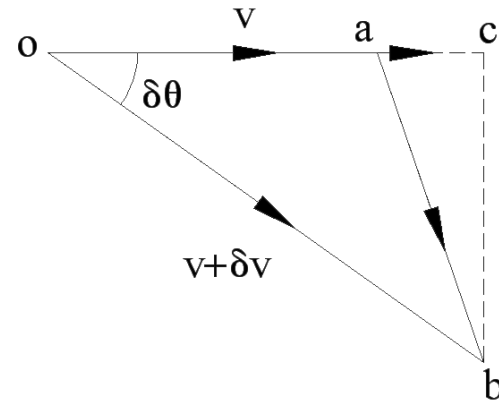
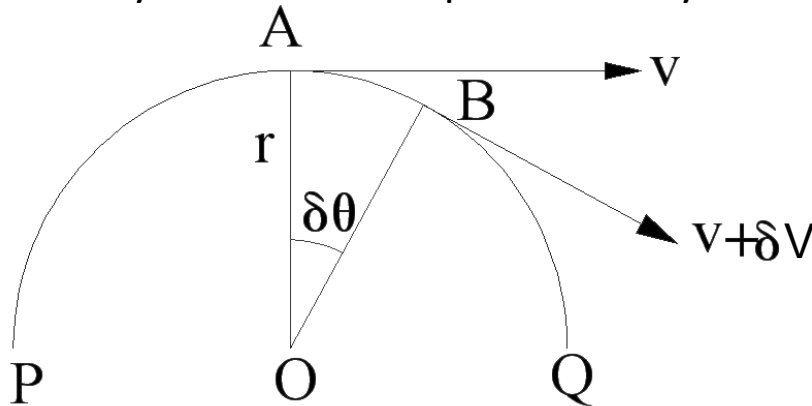

Now, resolving ab into two components i.e. parallel and perpendicular to oa .
Let ac and cb be the components parallel and perpendicular to oa respectively.

$$\begin{aligned}
 ac &= oc - ob \cos \delta\theta - oa \\
 &= (v + \delta v) \cos \delta\theta - v
 \end{aligned}$$

and $cb = ob \sin \delta\theta = (v + \delta v) \sin \delta\theta$

Since the change of velocity of particle (represented by vector ab) has two mutually perpendicular components therefore the acceleration of particle moving along a circular path has the following two component of acceleration which are perpendicular to each other.

➤ Tangential Component Of The Acceleration :-

The acceleration of a particle at any instant moving along a circular path in a direction tangential to that instant is known as tangential component of acceleration.

Therefore tangential component of the acceleration or tangential acceleration at A,

$$a_t = \frac{ac}{\delta t} = \frac{(v + \delta v) \cos \delta\theta - v}{\delta t}$$

In the limit when δt approaches to zero, then

$$a_t = dv / dt = \alpha \times r$$

➤ Normal Component Of The Acceleration :

The acceleration of a particle at any instant moving along a circular path in a direction normal to the tangent at that instant and directed towards the centre of the circular path (i.e. in the direction from A to O) is known as normal component of the acceleration. It is also called radial or centripetal acceleration.

Therefore Normal component of the acceleration of the particle at A or normal (or radial or centripetal) acceleration at A.

$$a_n = \frac{cb}{\delta t} = \frac{(v + \delta v) \sin \delta \theta}{\delta t}$$

In the limit, when δt approaches to zero, then

$$\begin{aligned} a_n &= v \times \frac{d\theta}{dt} = v \times \omega = v \times \frac{v}{r} \\ &= \frac{v^2}{r} = \omega^2 \times r \end{aligned}$$

Since the tangential acceleration (a_t) and the normal acceleration (a_n) of the particle at any instant A are perpendicular to each other, therefore total acceleration of the particle (a) is equal to the resultant acceleration of a_t and a_n .

Total acceleration or resultant acceleration ,

$$a = \sqrt{(a_t)^2 + (a_n)^2}$$



ACCELERATION DIAGRAM FOR A LINK

- Consider two points A and B on a rigid link as shown in Fig. a. Let the point B moves with respect to A, with an angular velocity of ω rad/sec. and let α rad/sec² be the angular acceleration of the link AB.
- The acceleration has two components:-
 - 1) Centripetal or radial component
 - 2) Tangential component

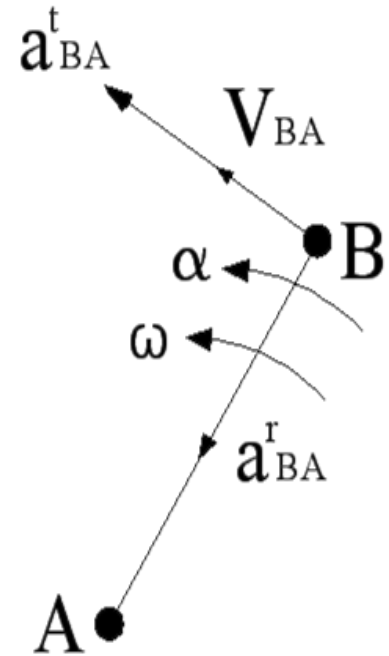

(a) Link

COMPONENTS OF ACCELERATION

Centripetal or radial component acts parallel to link and perpendicular to velocity V_{BA} .

It is denoted by a^r_{BA}

$$a^r_{BA} = \omega^2 \times \text{length of link AB}$$

Tangential component acts perpendicular to link and parallel to velocity V_{BA} .

It is denoted by a^t_{BA}

$$a^t_{BA} = \alpha \times \text{length of link AB}$$

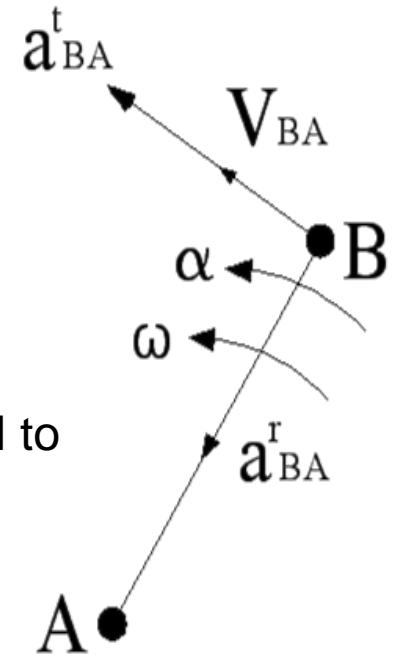

(a) Link

ACCELERATION DIAGRAM

In order to draw acceleration diagram for link AB

- Draw vector $b'x$ parallel to BA to represent radial component of acceleration of B with respect to A i.e. a_{BA}^r .
- From point x draw vector xa' perpendicular to BA to represent tangential component of acceleration of B with respect to A i.e. a_{BA}^t .
- Joint $b'a'$ which is known as acceleration image of link AB.

It represents the total acceleration of B with respect to A i.e. a_{BA}

It is the vector sum of radial component and tangential component of acceleration.

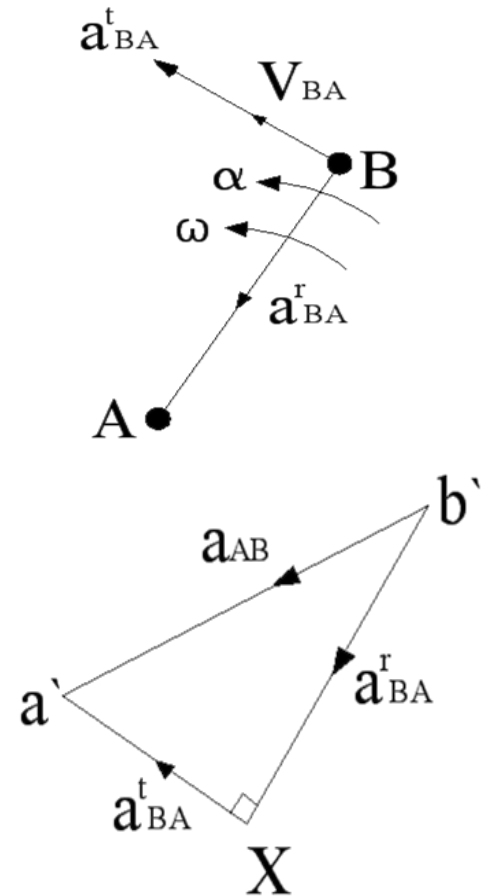

(b) Acceleration Diagram

ACCELERATION IN SLIDER CRANK MECHANISM

Given: $N_{BO} = 300$ r.p.m. , $OB = 150$ mm ,
 $BA = 600$ mm , $\theta = 45^\circ$

Find the angular acceleration of connecting rod and linear acceleration of slider.

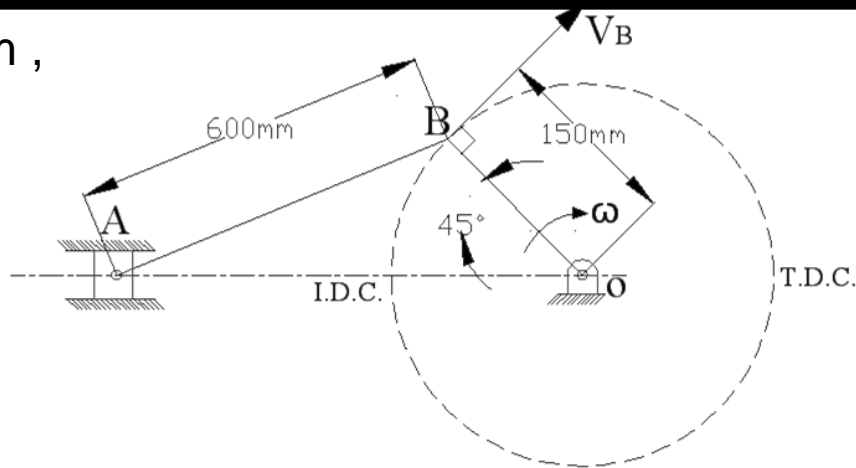

SLIDER CRANK MECHANISM

➤ Draw the configuration diagram of given mechanism with suitable scale.

➤ To find angular velocity of crank

$$\omega_B = \frac{2\pi N}{60} = \underline{\hspace{2cm}} \text{ rad /sec}$$

VELOCITY DIAGRAM

Draw the velocity diagram by velocity polygon method

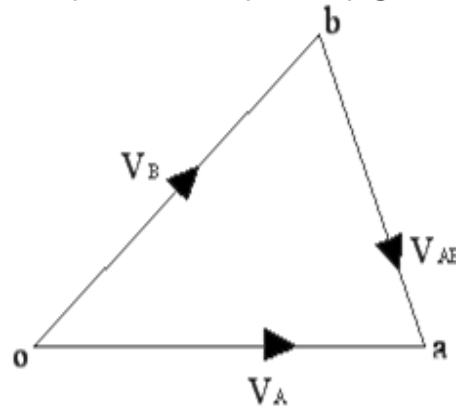

(b) velocity diagram.

Acceleration component of crank, connecting rod and slider :-

- Crank has centripetal or radial component of acceleration
- The connecting rod has both centripetal and tangential component of acceleration.
- The slider or piston has linear acceleration.

ACCELERATION DIAGRAM

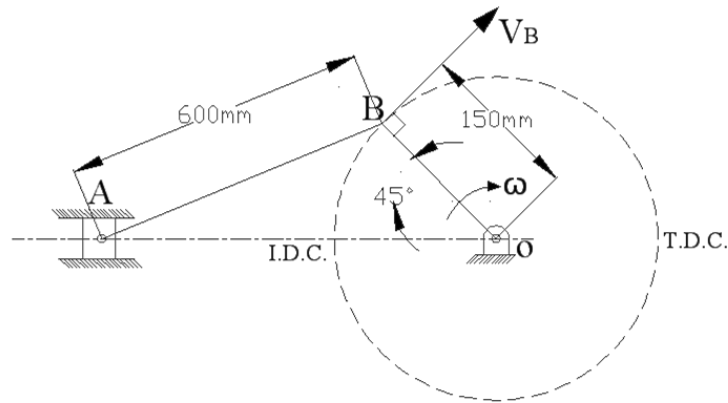

SLIDER CRANK MECHANISM

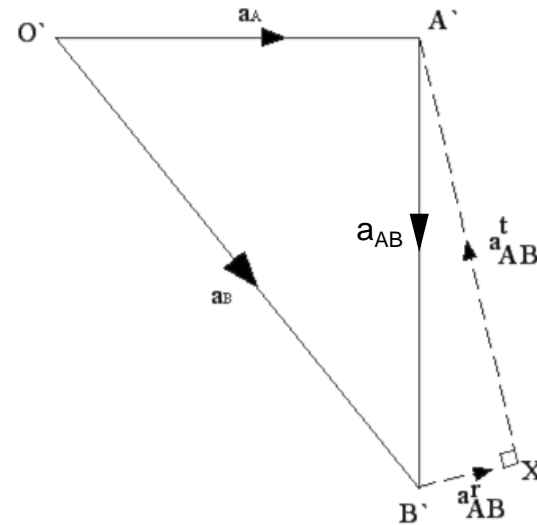

- Take any point **O'** draw vector (**O'B'**) parallel to link **OB** which gives radial component of acceleration and is given by

$$\text{Angular acceleration of crank } a_{OB}^r = \omega_{OB}^2 \times \text{length of link OB}$$

- Draw the vector (**B'X**) which is parallel to link **AB** (connecting rod) its magnitude of
The radial component of acceleration is given by

$$a_{AB}^r = \omega_{AB}^2 \times \text{length of link AB}$$

ACCELERATION DIAGRAM

- Draw the vector $(X - A')$ which is perpendicular to link **AB** (connecting rod) the magnitude of The tangential component of acceleration is given by

$$a_{AB}^t = \alpha \times \text{length of link AB}$$

- Draw the parallel line from **O'** the vector $(X-A')$ & $(O'A')$ intersect at point **A'**

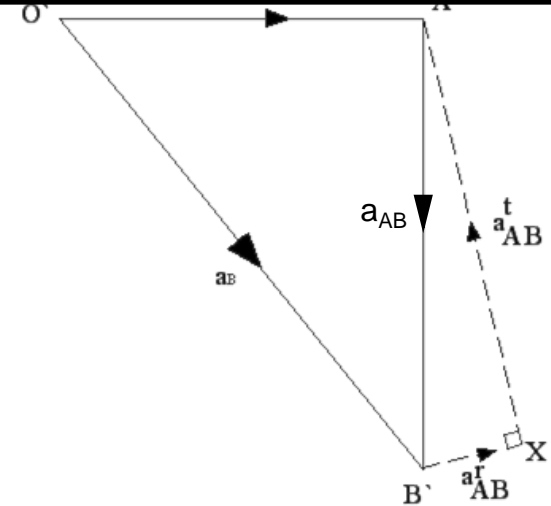

- By measurement we can find magnitude of tangential component of acceleration than we can find out angular acceleration of link AB(connecting rod)

$$\alpha = \frac{a_{AB}^t}{AB}$$

- The sum of vectors centripetal & tangential component of acceleration gives total acceleration represented by vector $(A'B')$



CORIOLIS COMPONENT OF ACCELERATION

- We have discussed the acceleration of a point with respect to another point on the same rigid link. It has two components of acceleration i.e. The vector sum of tangential acceleration f^t and centripetal acceleration f^c . This holds good when the distance between two points is fixed, and the relative acceleration of the two points on a moving rigid link is considered.
- If the distance between two points varies i.e., the second point which was stationary, now slides, the total acceleration will contain one additional component called as "CORIOLIS COMPONENT" of acceleration, represented by f^{cc} .

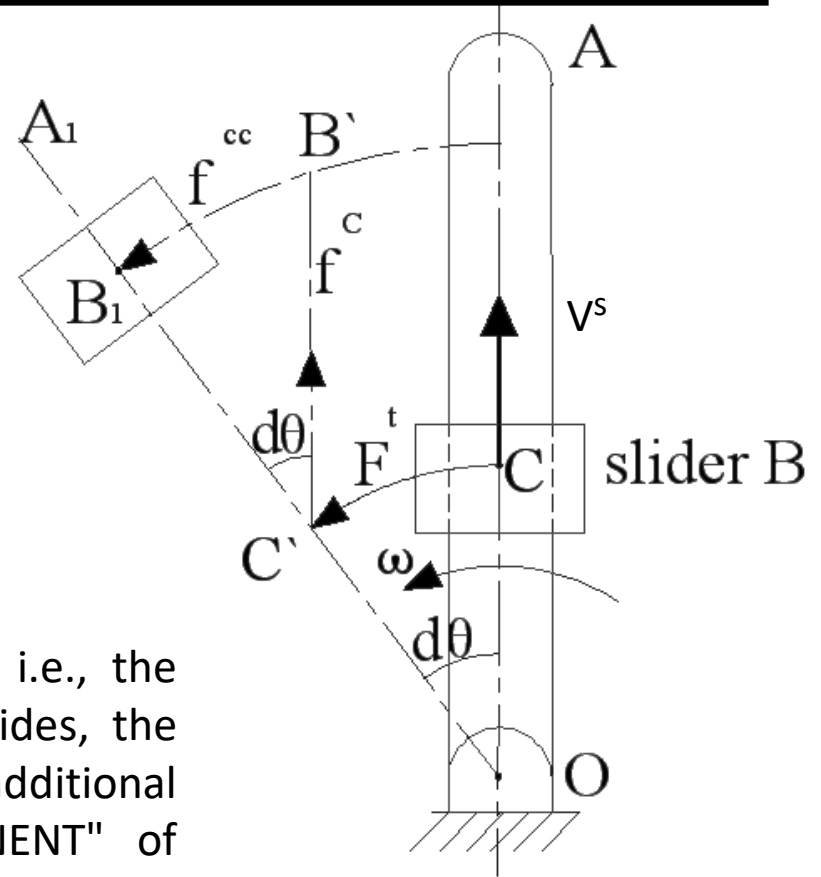

MAGNITUDE OF CORIOLIS COMPONENT

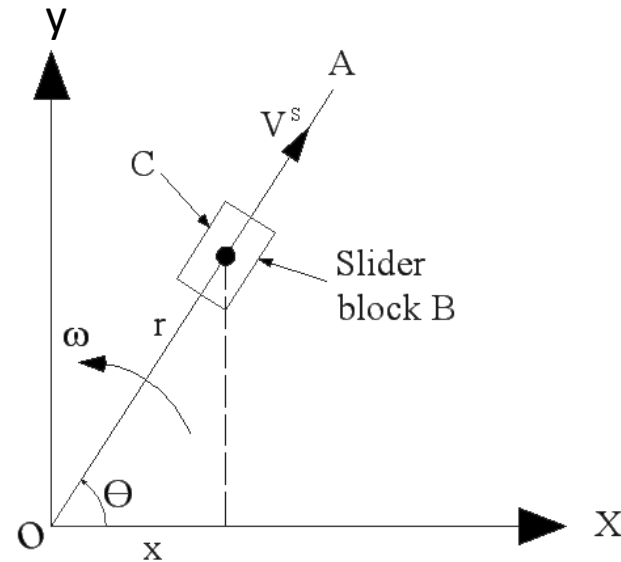
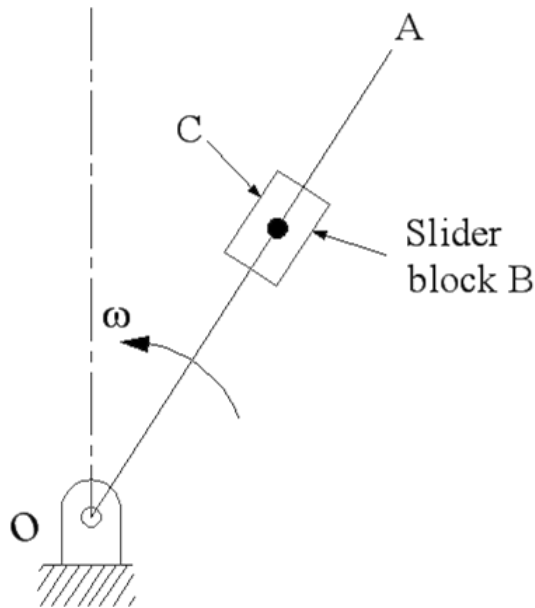

Consider a link OA rotating about O with a uniform angular velocity in anticlockwise direction. The slider block B is sliding along OA with a sliding velocity V^s . C is the point on OA which is instantaneously coincident with B as shown in diagram.

Coriolis component of acceleration (f^{cc}) is

$$f^{cc} = 2V^s\omega$$

METHOD OF FINDING THE DIRECTION

- In above expression, anticlockwise direction of ω is taken as positive and the outward direction of velocity of sliding, V^s is taken as positive.
- The direction of f^{cc} will be changed with change in direction of either ω or V^s or both.
- The direction of CORIOLIS component of acceleration can be determined by rotating the velocity of sliding vector V^s through 90° in the direction of rotation of angular velocity, ω .
- Figure shows the direction of $f^{cc} = 2V^s\omega$ for possible cases for given direction of ω and V^s .

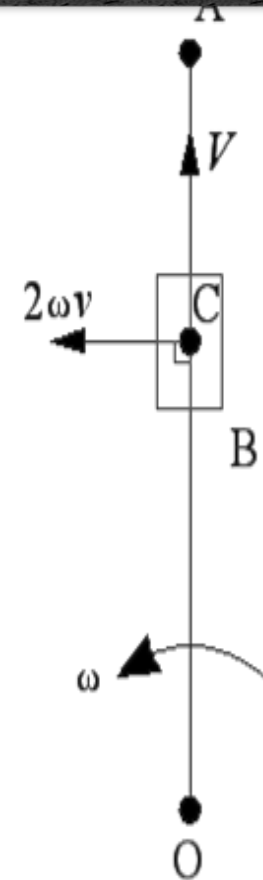

Four Possible cases :

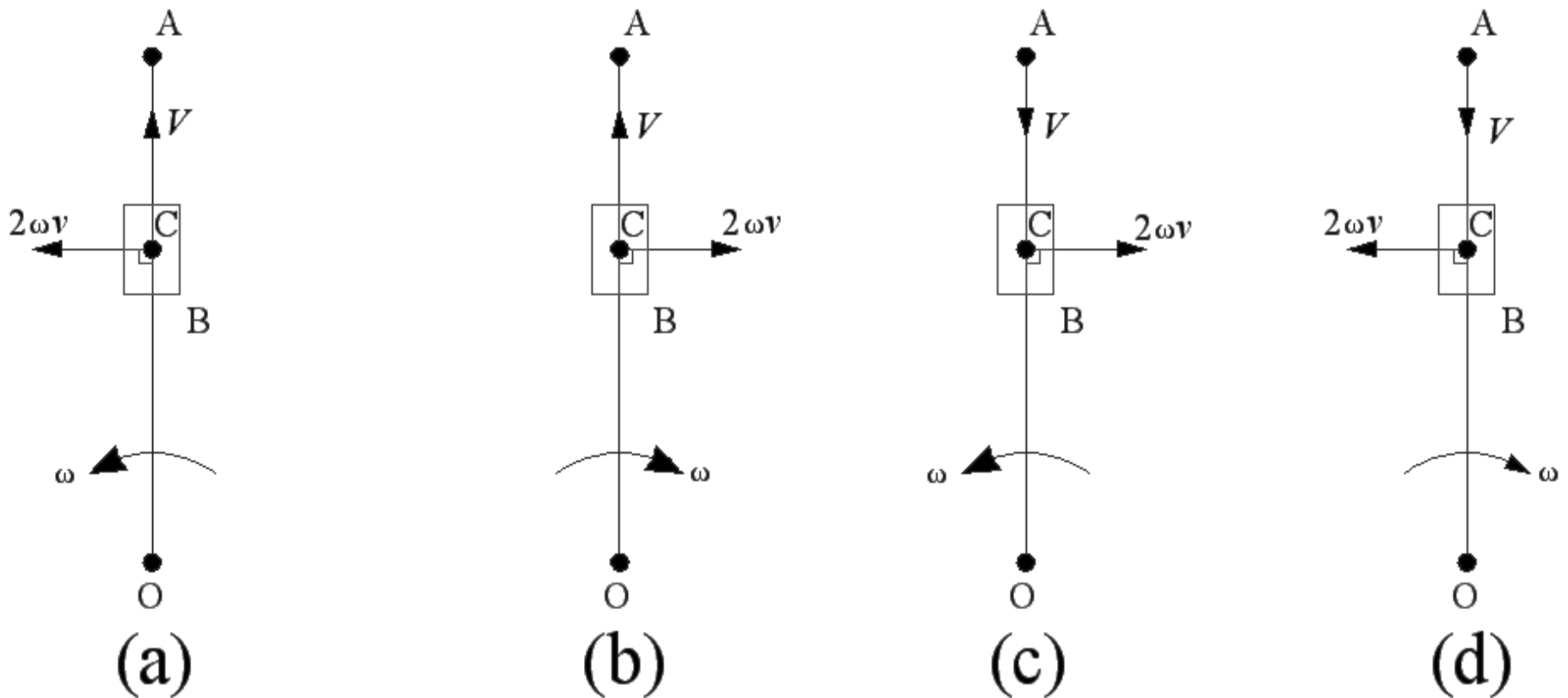

Direction of coriolis component of acceleration

Cont....

PROBLEM ON CORIOLIS COMPONENT

- Draw the configuration diagram of given mechanism with suitable scale.

- To find angular velocity of crank

$$\omega_{BA} = \frac{2\pi N}{60} = \text{_____ rad /sec}$$

- Linear velocity of link **BA** (V_{BA}) is

$$V_{BA} = \omega_{BA} \times BA = \text{_____ m/sec}$$

- Draw a velocity diagram from velocity polygon method

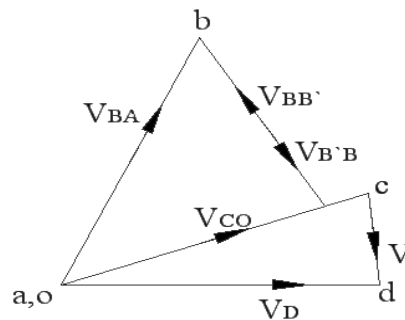

Velocity diagram

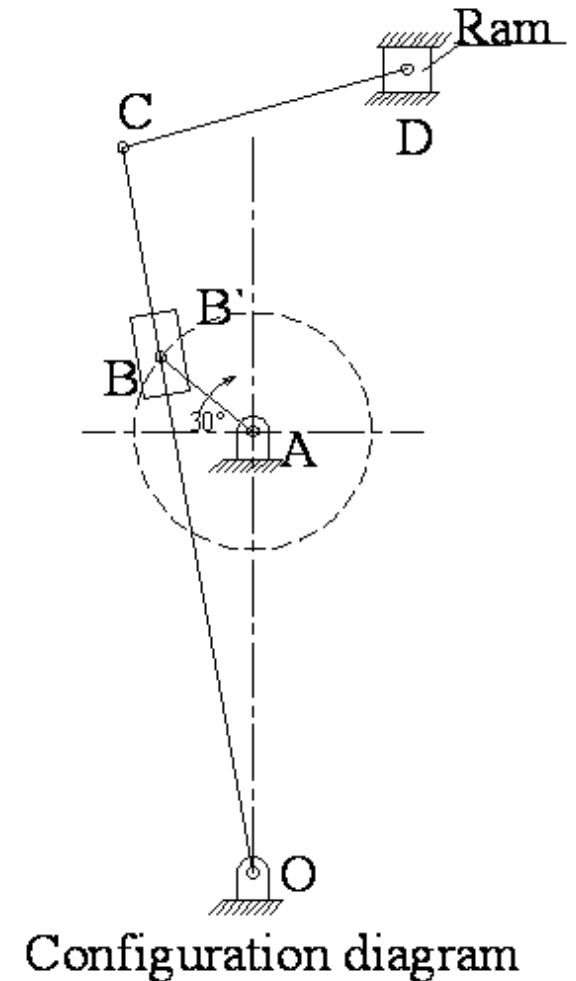

Configuration diagram

DIRECTION OF COMPONENT

- The direction of CORIOLIS component of acceleration can be determined by rotating the velocity of sliding vector V^s through 90° in the direction of rotation of angular velocity, ω .
- In given expression, clockwise direction of ω is taken as negative and the inward direction of velocity of sliding, V^s is taken as negative.

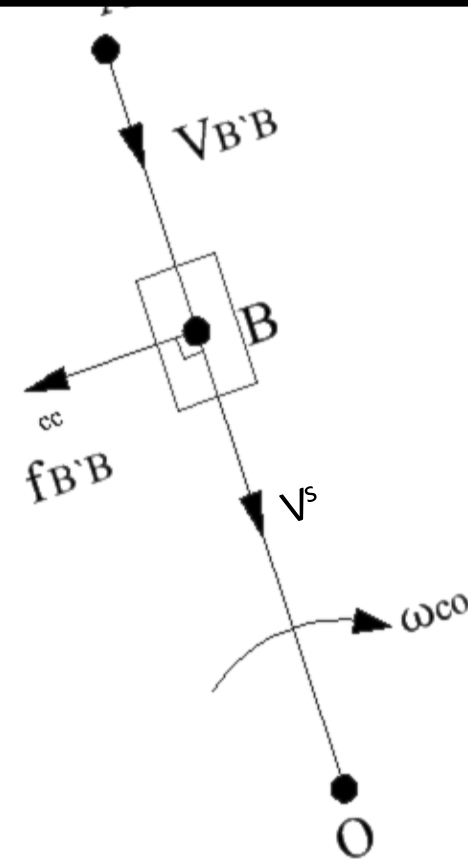

Direction of coriolis component

ACCELERATION DIAGRAM

PROCEDURE :-

First calculate the centripetal acceleration f^c
And tangential acceleration f^t of various links.

The Centripetal acceleration

$$f^c = v^2 / \text{length} \quad \text{m/sec}^2$$

The Tangential acceleration

$$f^t = \alpha \times \text{length} \quad \text{m/sec}^2$$

The coriolis component of acceleration :

$$f^{cc} = 2 v^s \omega \quad \text{m/sec}^2$$

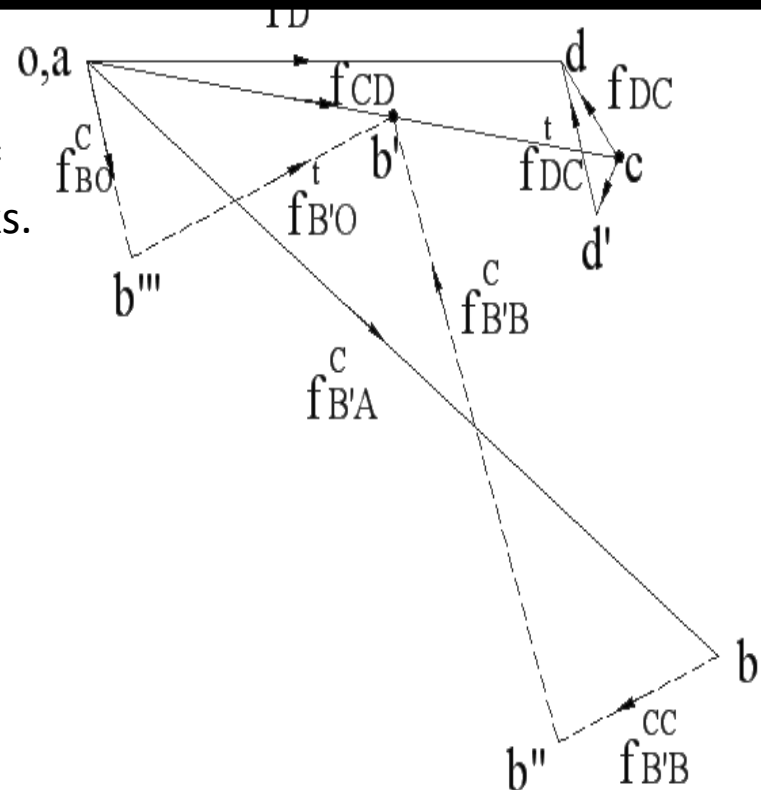

Acceleration diagram

Principles for acceleration

➤ Centripetal acceleration

If there is slider it has only linear acceleration.

➤ Tangential acceleration :-

if link rotates with uniform angular velocity is zero

By measurement on acceleration diagram calculate the acceleration of slider in m/sec^2 . and angular acceleration of slotted lever in rad/sec^2 .

UNIVERSITY QUESTION

- Crank radius and connecting rod length for an IC engine mechanism are 10cm and 40cm respectively. The crank is rotating uniformly at 1050 rpm clockwise. Using analytical method, find out the acceleration of piston as well as the angular acceleration of connecting rod when the crank is at 20° past the bottom dead center. **(June 2006)**Mark [16]

- In the internal combustion engine, the crank radius is 100 mm and the connecting rod length 500mm. the crank at 191 R.P.M. in anti-clockwise direction and has an acceleration of 125 rad/sec^2 . Use vector Algebra method and write the loop closure equation and find acceleration of the piston for a crank angle of 50° from the inner and centre. **(Dec 2006)**Mark [18]

- For the mechanism show in fig.3 find the acceleration of the slider B. Angular velocity of 'OA' is "18 rad/s" as shown.
(April 2005)Mark [16]

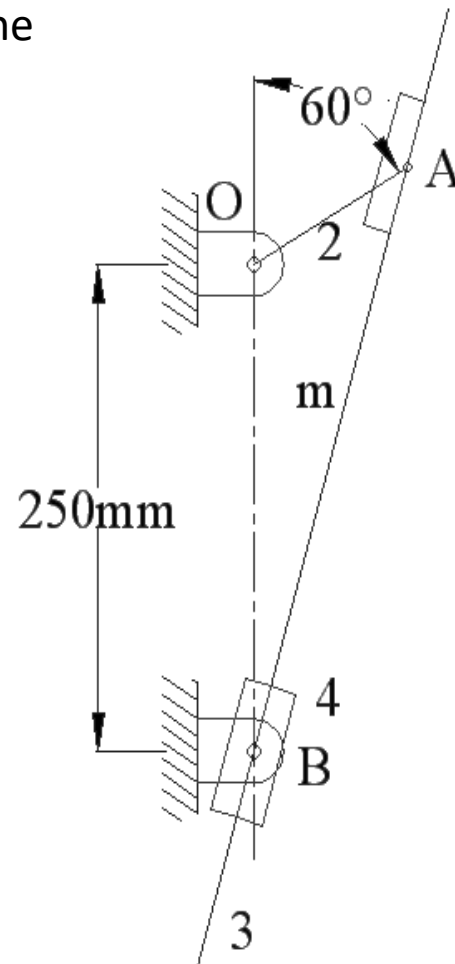

$$OA = 100 \text{ mm}$$
$$\omega = 18 \text{ rad/sec.}$$

Consider a point B on slider slides on rotating Link (Slotted Bar)
 And C (coincident to B) is point on Link (Slotted Bar) OA

Then **coriolis component of Acceleration** of B wrt C must be calculated

Here, consider the motion of the slider S from point S to S1 in the following three stages:

- S to Q_1 due to rotation of link OP.
- Q_1 to S' due to outward velocity V_{SQ} .
- S' to S_1 due to acceleration perpendicular to the link OP.

This third component is the Coriolis component of acceleration

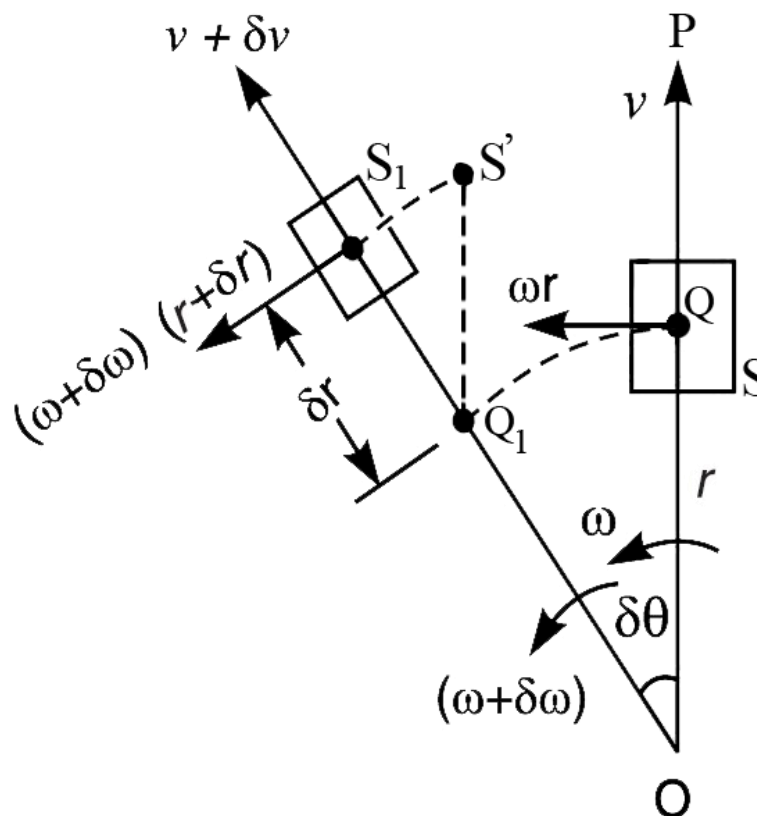

ω = Constant angular velocity of the link OP at time t.

v = Sliding velocity or Velocity of the slider S along the link OP at time t.

$r.\omega$ = Tangential velocity or Velocity of the slider S with respect to O
(perpendicular to the link OP)

$(\omega + \delta\omega), (v + \delta v) \& (\omega + \delta\omega) \cdot (r + \delta r)$ = Corresponding values at time $(t + \delta t)$ seconds

- The vector 'ss₁' represents the change in velocity in time δt sec
- The vector 'sa' represents the component of change of velocity 'ss₁' along radial direction (i.e. along OP)
- Vector 's₁a' represents the component of change of velocity 'ss₁' in a direction perpendicular to OP (i.e. in tangential direction).

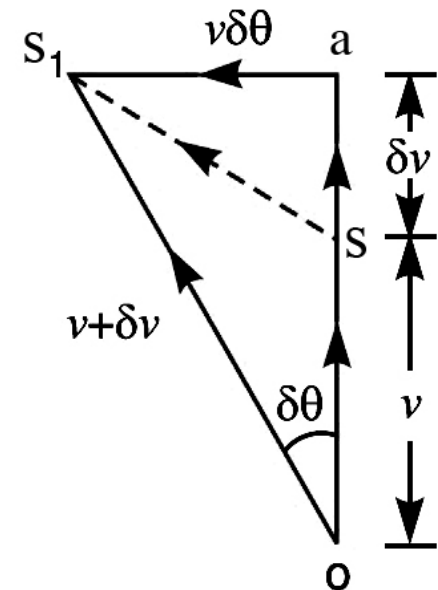

Direction of Coriolis Component of Acceleration.

The directional relationship of sliding velocity v and angular velocity of link ω can be enunciated as follows:

The direction of Coriolis component of acceleration is the direction of relative velocity vector for the two coincident points rotated by 90° in the direction of the angular velocity of the rotation of the link

Let's understand it with simple terms

In fig.6.5(a) assume velocity vector ' v ' in the direction of QP i.e. radially outwards. Now because the link is rotating in the clockwise sense, rotate this velocity vector in **clockwise direction by 90°** as shown. This gives the direction of coriolis component of acceleration towards the right of the link.

Similarly, fig.6.5(b) assume velocity vector in the direction of QO. Now because the link is rotating in the anticlockwise sense, rotate velocity vector in **clockwise direction by 90°** as shown. This gives the direction of coriolis component of acceleration towards the left of the link.

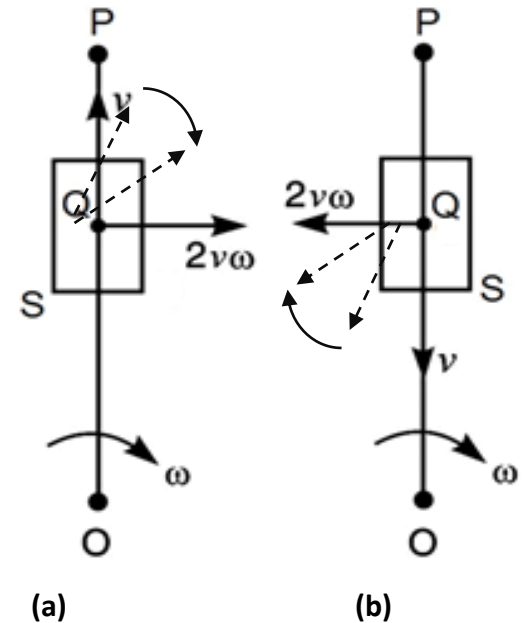

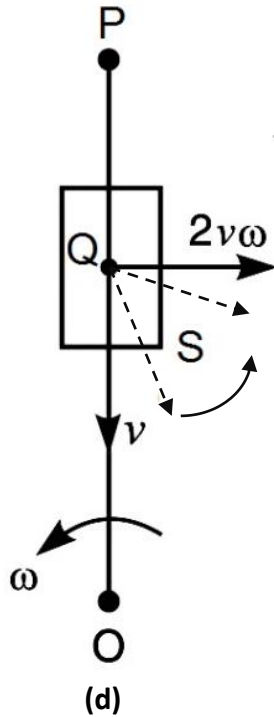
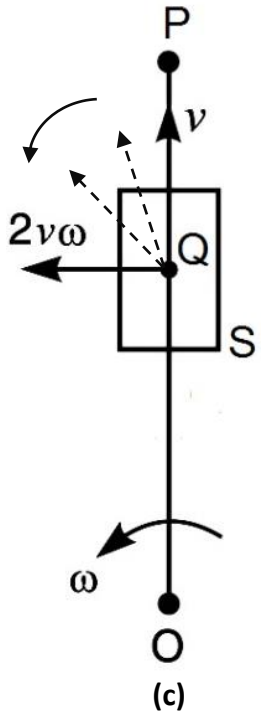

In fig.6.5(c) assume velocity vector in the direction of QP. Now because the link is rotating in the anticlockwise sense, rotate velocity vector in **anticlockwise direction by 90°** as shown. This gives the direction of coriolis component of acceleration towards the left of the link.

Similarly fig.6.5(d) assume velocity vector in the direction of QO. Now because the link is rotating in the anticlockwise sense, rotate velocity vector in **anticlockwise direction by 90°** as shown. This gives the direction of coriolis component of acceleration towards the right of the link.

The anticlockwise direction for ' ω ' and the radially outward direction for ' v ' are taken as **positive**. The direction of coriolis component of acceleration changes if direction of ' ω ' or ' v ' alters. But, if direction of both ω and v alters, coriolis component of acceleration directed towards positive side. It is concluded that the direction of coriolis component of acceleration is obtained by rotating v , at 90° , about its origin in the same direction as that of ω .

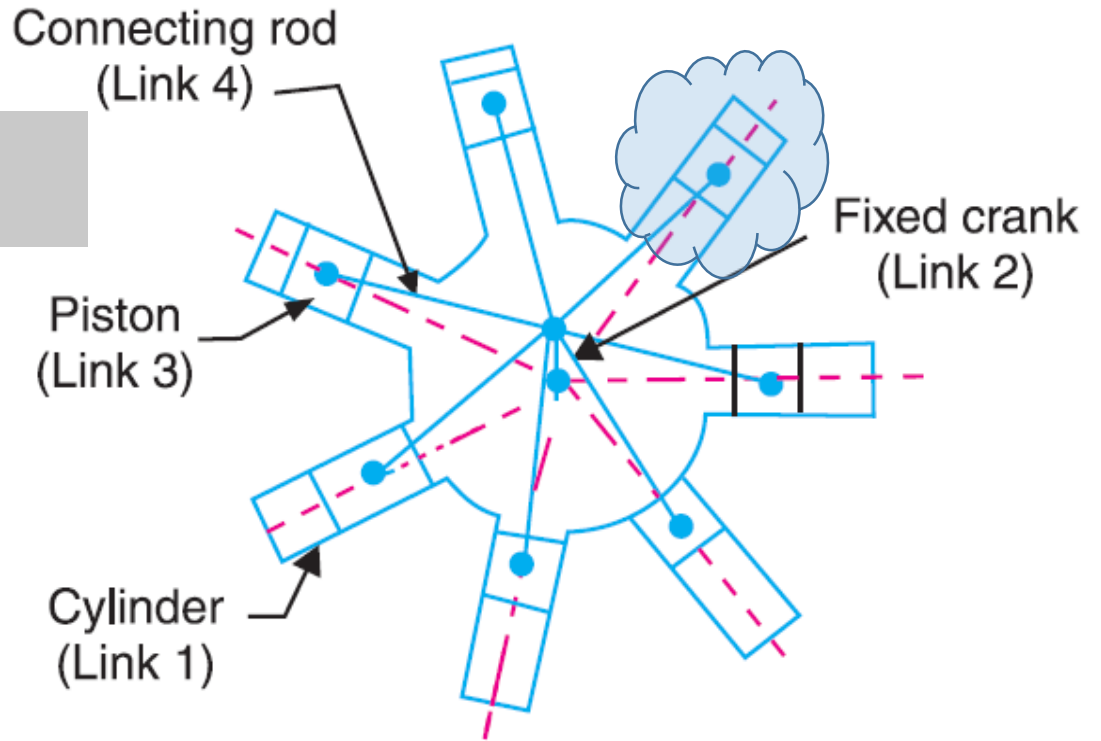
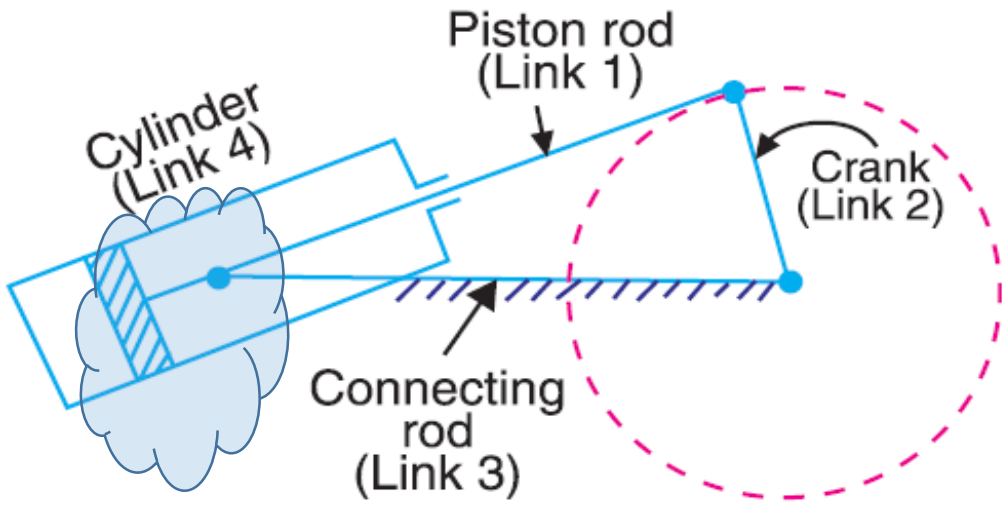

Few mechanisms involving CORIOLIS component of Acceleration

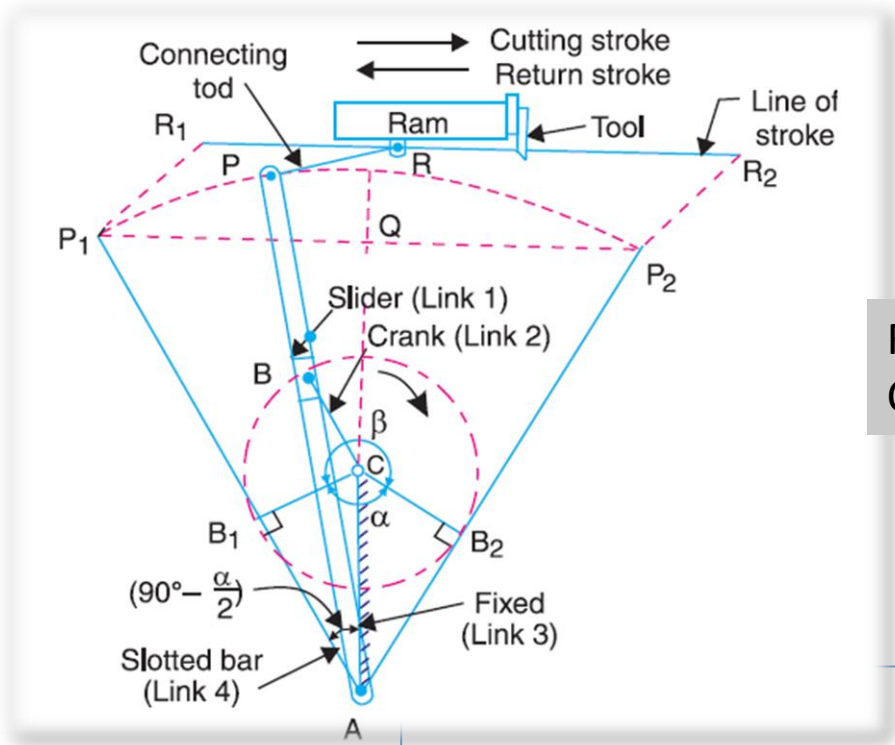

Few mechanisms involving CORIOLIS component of Acceleration

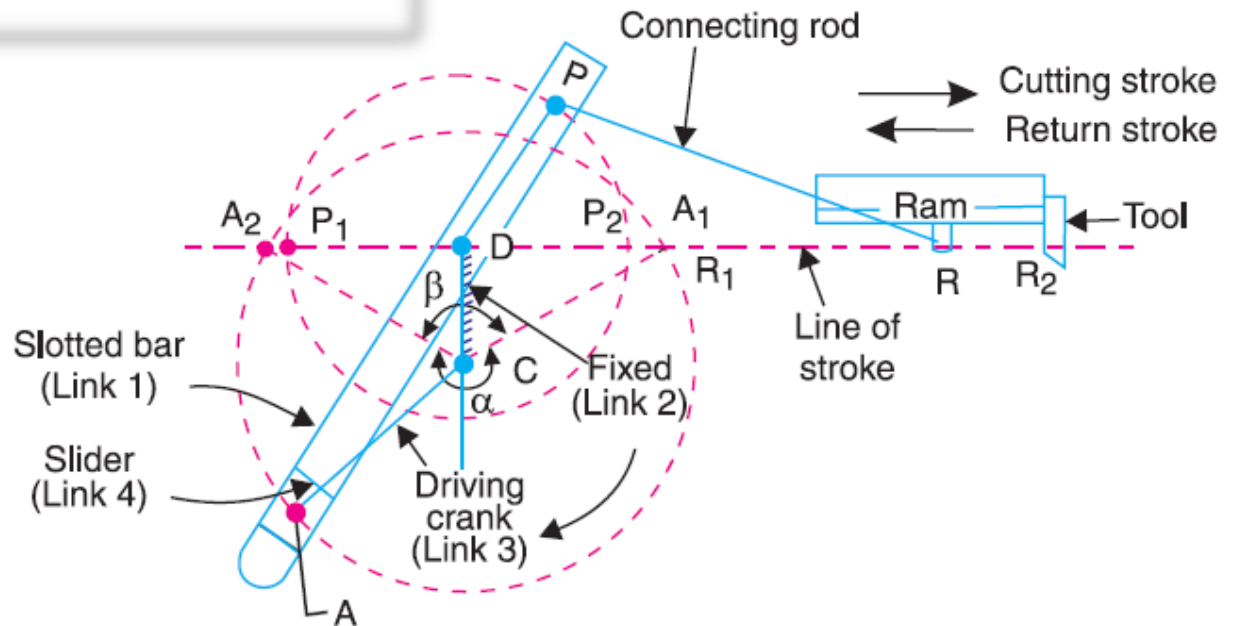

SWIVEL Joint
mechanisms involving
CORIOLIS component of Acceleration

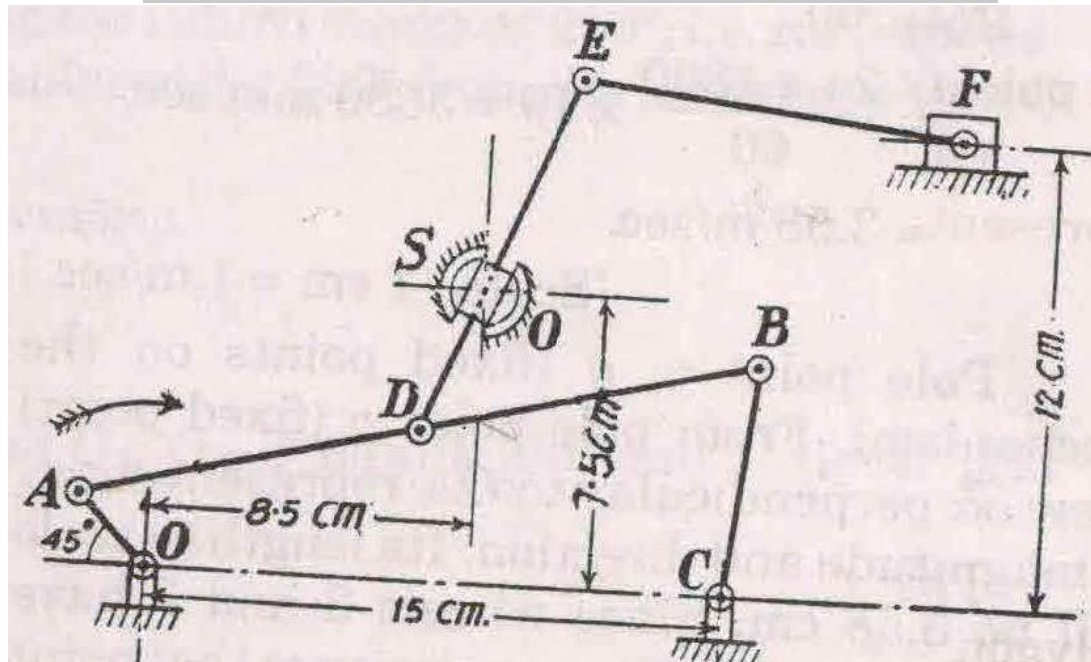

AND few mechanisms **NOT** involving
CORIOLIS component of Acceleration

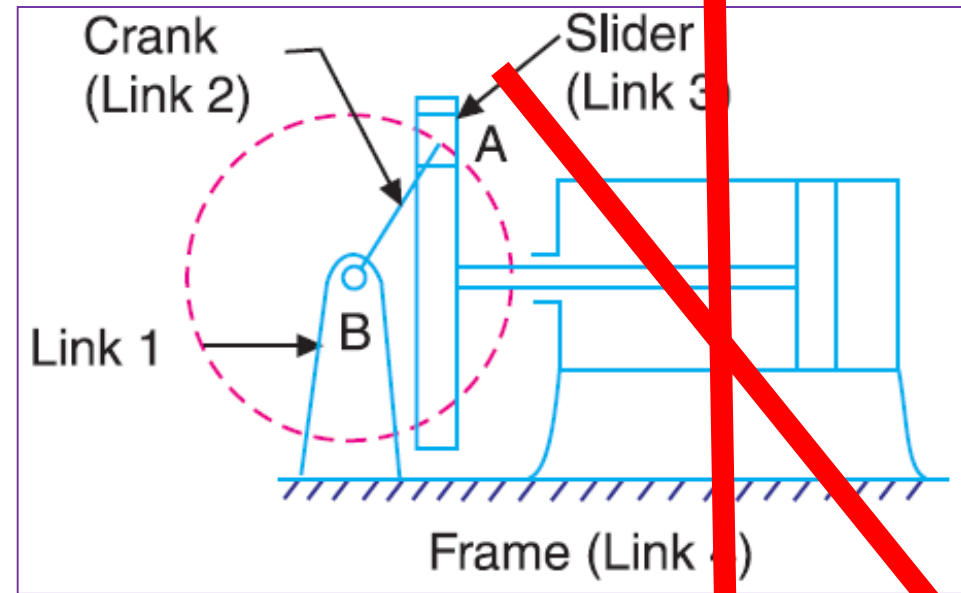
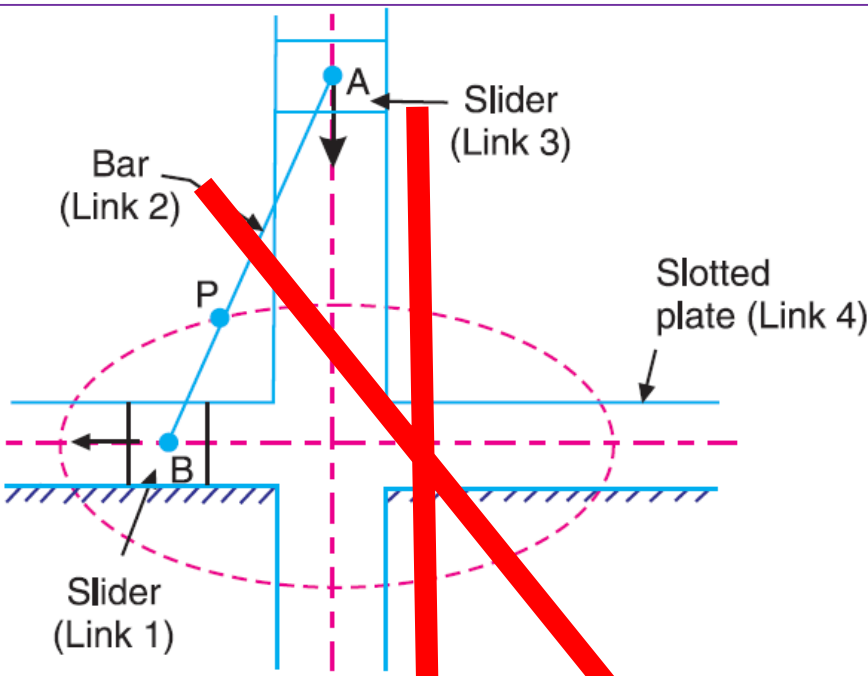

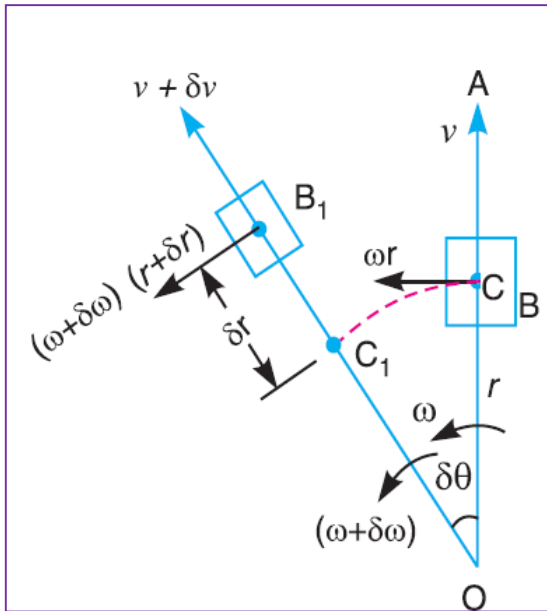

B and **C** are coincident points

B is point on Slider

C is point on rotating slotted bar OA

Acceleration of B wrt C has two components

i) **Coriolis component** (Tangential component)

ii) Sliding component (Radial outward)

$$a_{BC}^r = \frac{dV}{dt}$$

Magnitude of

CORIOLIS component of acceleration is given by

$$a_{BC}^{cr} = 2\omega_{OA} V_{BC}$$

Direction of

CORIOLIS component of acceleration is given by

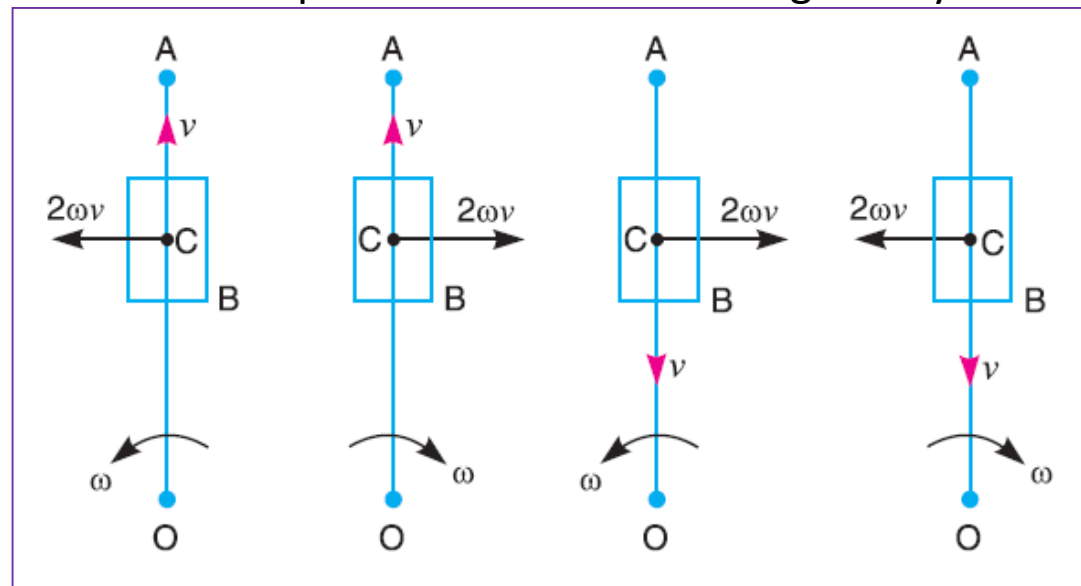

Numerical 1

Example 8.13. A mechanism of a crank and slotted lever quick return motion is shown in Fig. 8.28. If the crank rotates counter clockwise at 120 r.p.m., determine for the configuration shown, the velocity and acceleration of the ram D. Also determine the angular acceleration of the slotted lever.

Crank, $AB = 150 \text{ mm}$; Slotted arm, $OC = 700 \text{ mm}$ and link $CD = 200 \text{ mm}$.

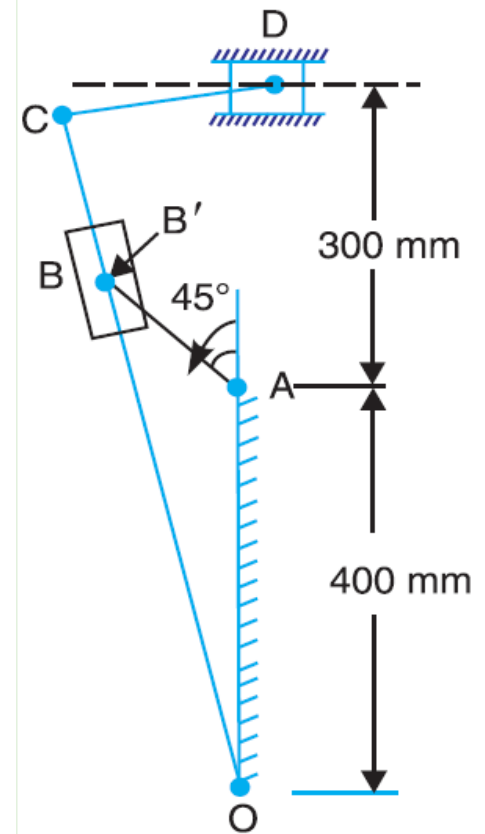

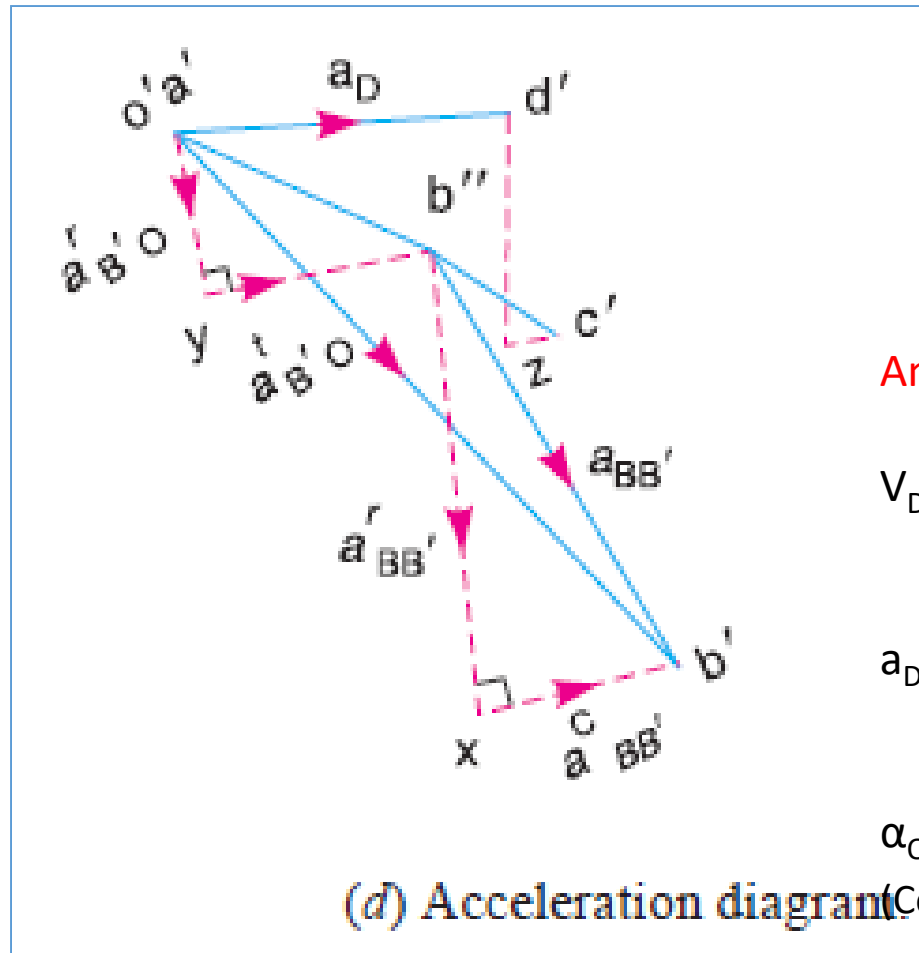
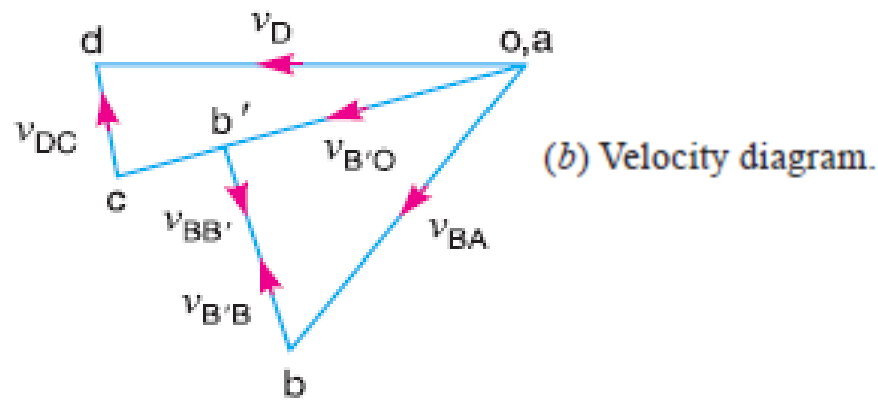
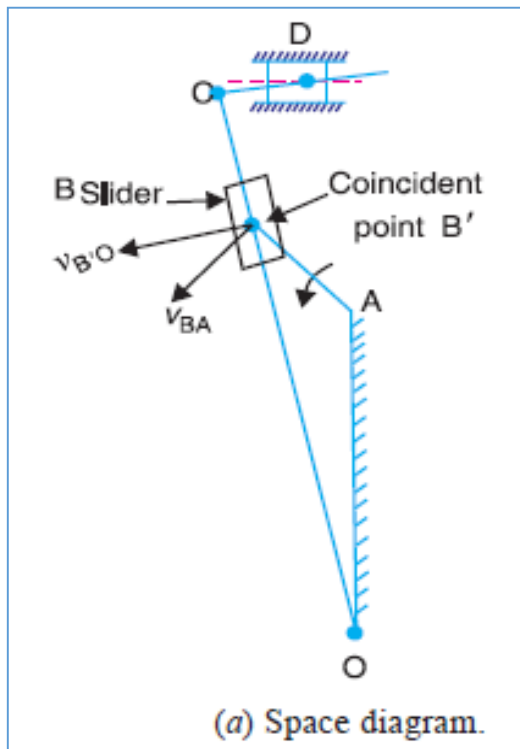

Answers:

$$V_D = 2.15 \text{ m/s}$$

$$a_D = 8.4 \text{ m/s}^2$$

$$\alpha_{OB'} = 12.3 \text{ rad/s}^2$$

(CounterClockwise)

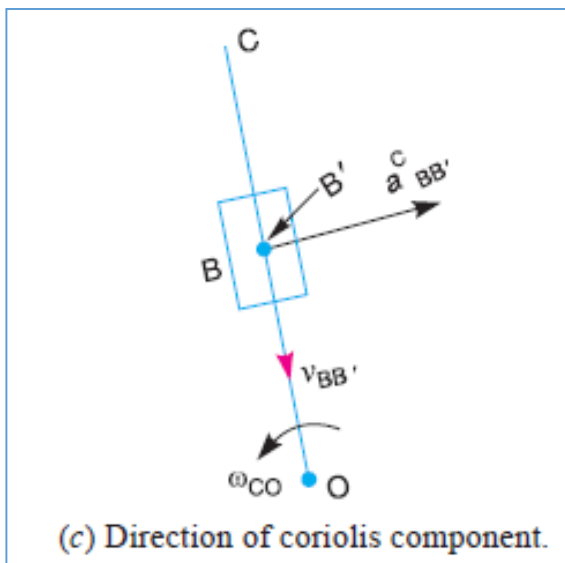

Numerical 2

The mechanism as shown in Fig is a marine steering gear, called Rapson's slide. O_2B is the tiller and AC is the actuating rod. If the velocity of AC is 25 mm/min to the left, find the angular velocity and angular acceleration of the tiller. Either graphical or analytical technique may be used.

[Ans. 0.125 rad/s; 0.018 rad/s²]

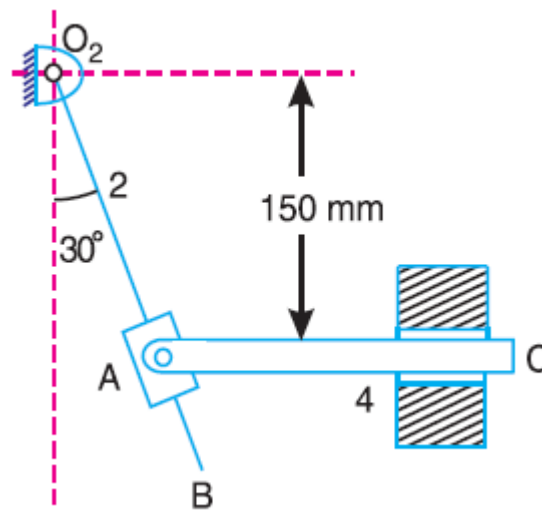

ACCELERATION DIAGRAM

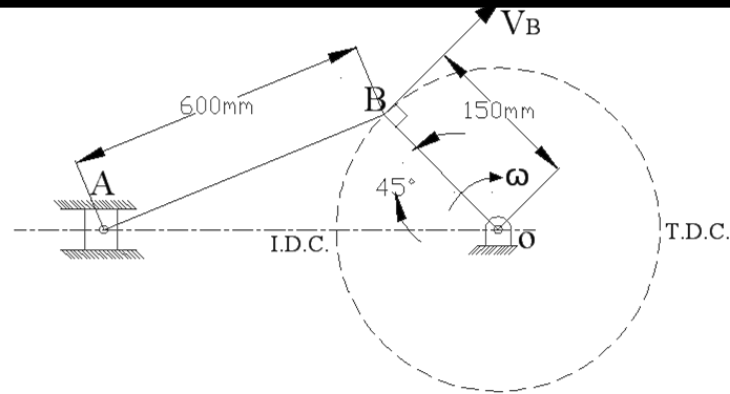

SLIDER CRANK MECHANISM

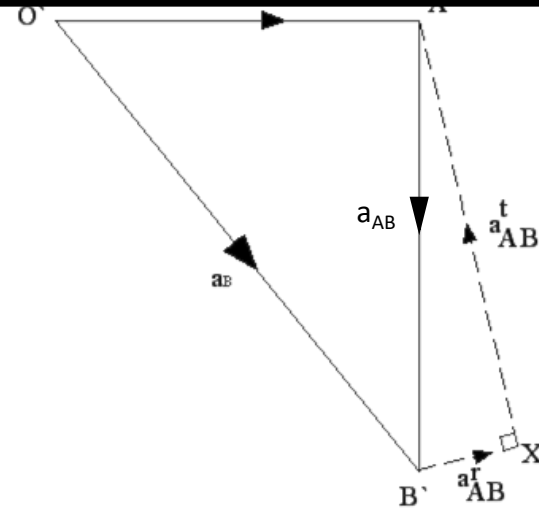

- Take any point **O'** draw vector (**O'B'**) parallel to link **OB** which gives radial component of acceleration and is given by

$$\text{Angular acceleration of crank } a_{OB}^r = \omega_{OB}^2 \times \text{length of link OB}$$

- Draw the vector (**B'X**) which is parallel to link **AB** (connecting rod) its magnitude of

The radial component of acceleration is given by

$$a_{AB}^r = \omega_{AB}^2 \times \text{length of link AB}$$

ACCELERATION DIAGRAM

- Draw the vector $(X - A')$ which is perpendicular to link **AB** (connecting rod) the magnitude of The tangential component of acceleration is given by

$$a_{AB}^t = \alpha \times \text{length of link AB}$$

- Draw the parallel line from O' the vector $(X-A')$ & $(O'A')$ intersect at point A'

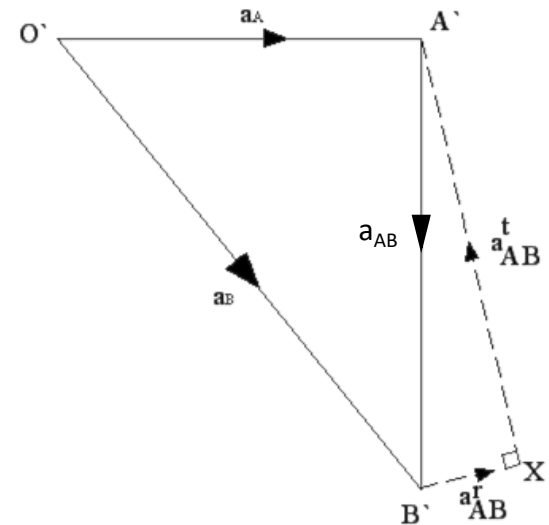

- By measurement we can find magnitude of tangential component of acceleration than we can find out angular acceleration of link AB(connecting rod)

$$\alpha = \frac{a_{AB}^t}{AB}$$

- The sum of vectors centripetal & tangential component of acceleration gives total acceleration represented by vector $(A'B')$



CORIOLIS COMPONENT OF ACCELERATION

- We have discussed the acceleration of a point with respect to another point on the same rigid link. It has two components of acceleration i.e. The vector sum of tangential acceleration f^t and centripetal acceleration f^c . This holds good when the distance between two points is fixed, and the relative acceleration of the two points on a moving rigid link is considered.
- If the distance between two points varies i.e., the second point which was stationary, now slides, the total acceleration will contain one additional component called as "CORIOLIS COMPONENT" of acceleration, represented by f^{cc} .

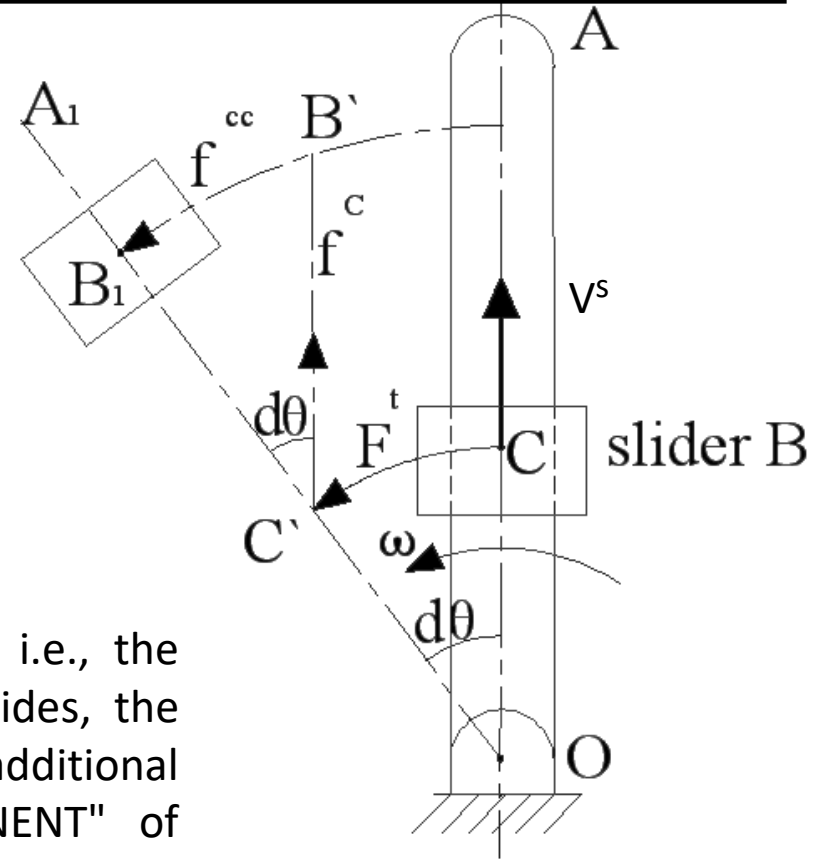

MAGNITUDE OF CORIOLIS COMPONENT

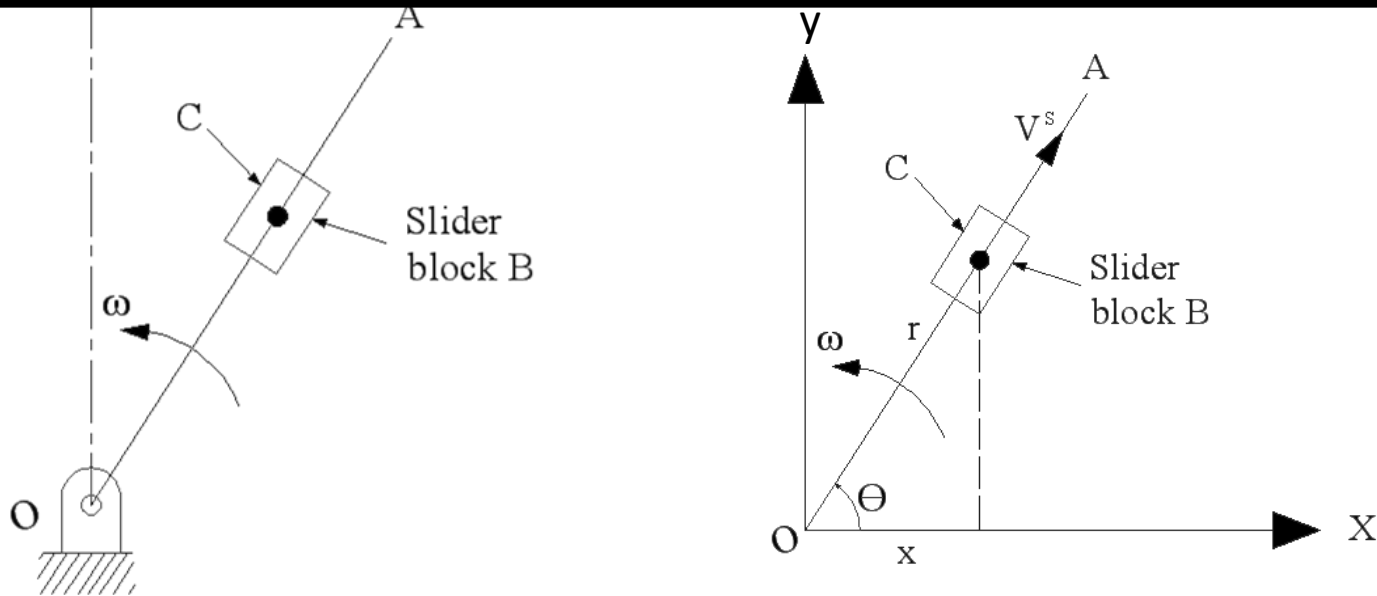

Consider a link OA rotating about O with a uniform angular velocity in anticlockwise direction. The slider block B is sliding along OA with a sliding velocity V^s . C is the point on OA which is instantaneously coincident with B as shown in diagram.

Coriolis component of acceleration (f^{cc}) is

$$f^{cc} = 2V^s\omega$$

METHOD OF FINDING THE DIRECTION

- In above expression, anticlockwise direction of ω is taken as positive and the outward direction of velocity of sliding, V^s is taken as positive.
- The direction of f^{cc} will be changed with change in direction of either ω or V^s or both.
- The direction of CORIOLIS component of acceleration can be determined by rotating the velocity of sliding vector V^s through 90° in the direction of rotation of angular velocity, ω .
- Figure shows the direction of $f^{cc} = 2V^s\omega$ for possible cases for given direction of ω and V^s .

